



FM30R080P 30AMP DC FILTER MODULE

Application Note V11 May 2020

FM30R080P 30AMP DC FILTER MODULE



Approved By:

Department	Approved By	Checked By	Written By
Research and Development Department	Enoch	Astray	Jiawei
		Jacky	
Quality Assurance Department	Ryan	Benny	



FM30R080P 30AMP DC FILTER MODULE

Application Note V11 May 2020

Content

1. INTRODUCTION	3
2. FEATURES	3
3. ELECTRICAL CIRCUIT DIAGRAM	3
4. TECHNICAL SPECIFICATIONS	4
5. MAIN FEATURES AND FUNCTIONS	5
5.1 Operating Temperature Range	5
5.2 Insertion Loss	5
6. APPLICATIONS	5
6.1 Recommend Layout, PCB Footprint and Soldering Information	5
6.2 Thermal Considerations	5
6.3 Output Remote Sensing	6
6.4 Power Derating	7
6.5 Quarter Brick Heat Sinks:	9
7. CONNECTION FOR STANDARD USE	10
8. PART NUMBER	17
9. MECHANICAL OUTLINE DIAGRAMS	17
9.1 FM30R080P Mechanical Outline Diagrams	17



FM30R080P 30AMP DC FILTER MODULE

Application Note V11 May 2020

1. Introduction

FM30R080P filter module is created to accommodate the need to meet Railway standards of EN55015 for EN50121-3-2:2015 output conducted specification standard, and Fire & Smoke EN45545-2. This standard filter simplifies the process of meeting the necessary requirements for Railway applications. The filter module is designed to reduce common mode and differential mode noise of the DC converter. The FM30R080P filter module offers maximum current rating of 30A and maximum rated voltage up to 80V.

It has industry Quarter-Brick size. Allowing case operating temperature range of -40°C to 110°C . An optional heat sink is available to extend the full power range of the unit. The filter module provides excellent thermal performance. FM30R080P is designed primarily for common railway applications and suitable for distributed power architectures, telecommunications, battery operated equipment and industrial applications.

2. Features

- * Compact Size 2.28"x1.45"
- * Quarter-Brick Size
- * Six-Sided Shield Metal Case
- * PCB Mount
- * 30A Filter Module
- * 80VDC Rated Voltage Maximum
- * Suitable for EN50121-3-2:2015 Output Specification
- * Fire & Smoke Meets EN45545-2

3. Electrical Circuit Diagram

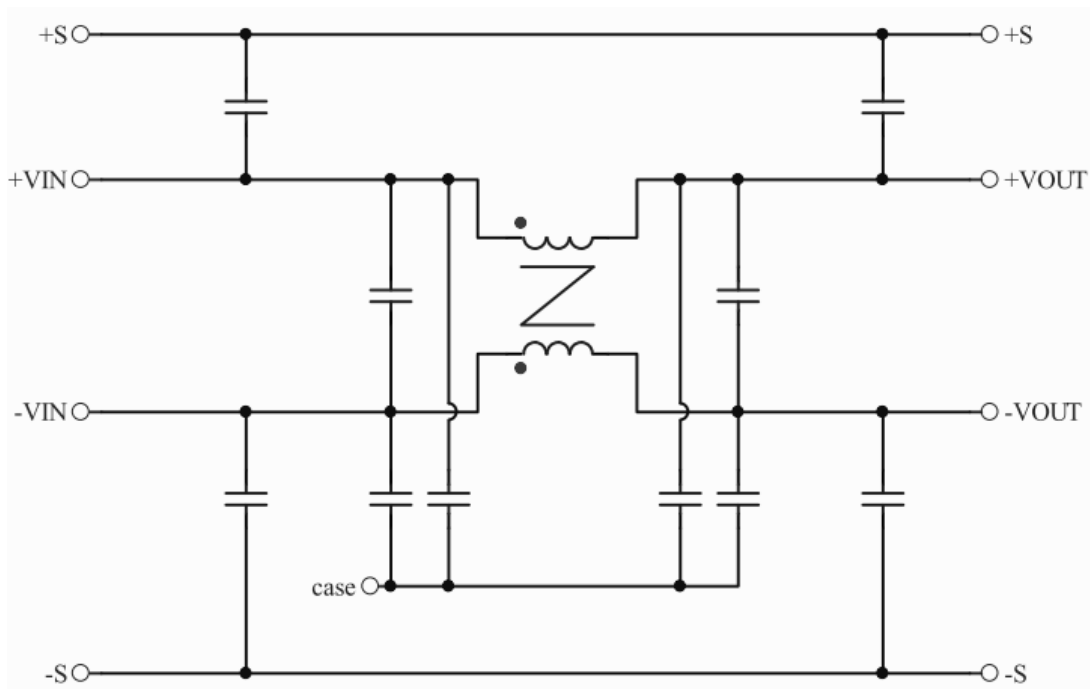

Figure1 Internal Schematic for FM30R080P Module



FM30R080P 30AMP DC FILTER MODULE

Application Note V11 May 2020

4. Technical Specifications

(All specifications are typical at nominal input, full load at 25°C unless otherwise noted.)

ABSOLUTE MAXIMUM RATINGS

PARAMETER	NOTES and CONDITIONS	Device	Min.	Typical	Max.	Units
Input Voltage						
Continuous		All			80	V _{dc}
Transient	1 second	All			100	V _{dc}
Operating Temperature	see derating curve	All	-40		+110	°C
Storage Temperature		All	-55		+125	°C

ELECTRICAL CHARACTERISTICS

PARAMETER	NOTES and CONDITIONS	Device	Min.	Typical	Max.	Units
Operating Voltage Range		All	0		80	V _{dc}
Operating Current Range		All	0		30	A
Input Surge Voltage	1 second	All			100	V _{dc}
DC Resistance	+Input to +Output.	All		2	3	mΩ
	-Input to -Output	All		2	3	mΩ

ISOLATION CHARACTERISTICS

PARAMETER	NOTES and CONDITIONS	Device	Min.	Typical	Max.	Units
Isolation Voltage	1 minute; input to case, output to case	All			1000	V _{dc}
Isolation Resistance	500Vdc, input to case, output to case	All	100			MΩ
Isolation Capacitance	input to case, output to case	All		0.1		uF

GENERAL SPECIFICATIONS

PARAMETER	NOTES and CONDITIONS	Device	Min.	Typical	Max.	Units
Weight		All		60		grams
Case Material	Aluminum with Non-Conducted Base					
Potting Material	UL 94V-0					
Shock/Vibration	Meets EN50155 (EN61373)					
Humidity	95% RH max. Non-Condensing					
Thermal Shock	Meets MIL-STD-810F					
Fire & Smoke	Meets EN45545-2					



FM30R080P 30AMP DC FILTER MODULE

Application Note V11 May 2020

5. Main Features and Functions

5.1 Operating Temperature Range

The FM30R080P filter module has resulted in their ability to operate within ambient temperature environments from -40°C to 110°C . The derating curve was drawn from the FM30R080P module.

- Output load current
- Forced air or natural convection
- Heat sink optional

5.2 Insertion Loss

The filter module is designed to reduce common mode and differential mode noise of the DC converter. The typical characteristics see below.



Figure 2. Typical Common-Mode Insertion Loss



Figure 3. Typical Differential-Mode Insertion Loss

6. Applications

6.1 Recommend Layout, PCB Footprint and Soldering Information

The system designer or end user must ensure that metal and other components in the vicinity of the module meet the spacing requirements for which the system is approved. Low resistance and inductance PCB layout traces are the norm and should be used where possible.

Due consideration must also be given to proper low impedance tracks between power module, input and output grounds. The recommended soldering profile and PCB layout are shown below.

Lead Free Wave Soldering Profile

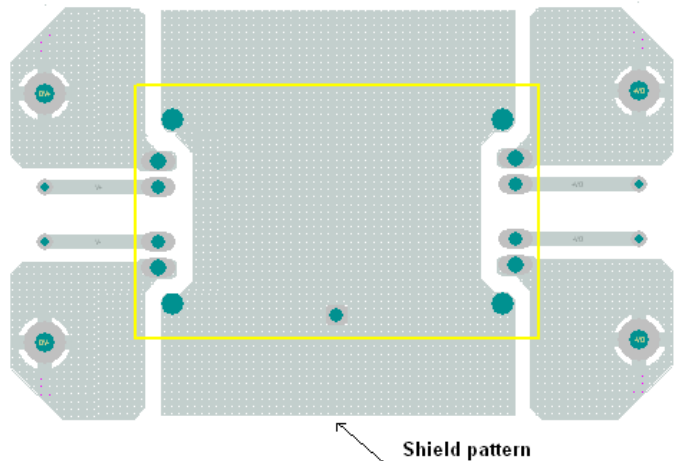
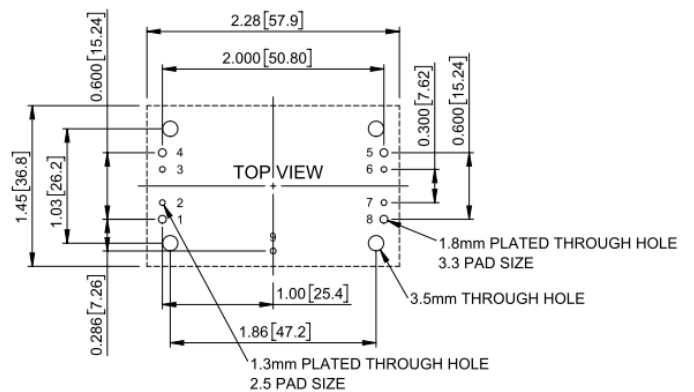
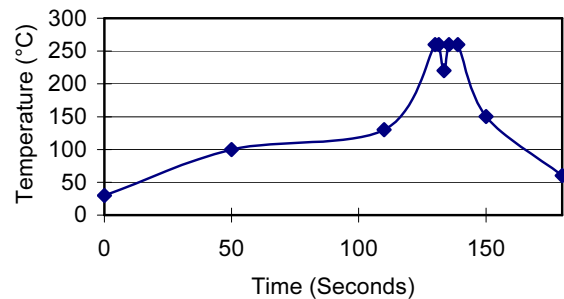

6.2 Thermal Considerations

The module operates in a variety of thermal environments; however, sufficient cooling should be provided to help ensure reliable operation of the unit. Heat is removed by conduction, convection, and radiation to the surrounding environment. The example is presented in **section 6.4**. The current output of the module should not be allowed to exceed rated current.



FM30R080P 30AMP DC FILTER MODULE

Application Note V11 May 2020

6.3 Output Remote Sensing

The FM30R080P output filter module has the capability to remotely sense both lines of its output. This feature moves the effective output voltage regulation point from the output of the unit to the point of connection of the remote sense pins. This feature automatically adjusts the real output voltage of the converter in order to compensate for voltage drops in distribution and maintain a regulated voltage at the point of load.

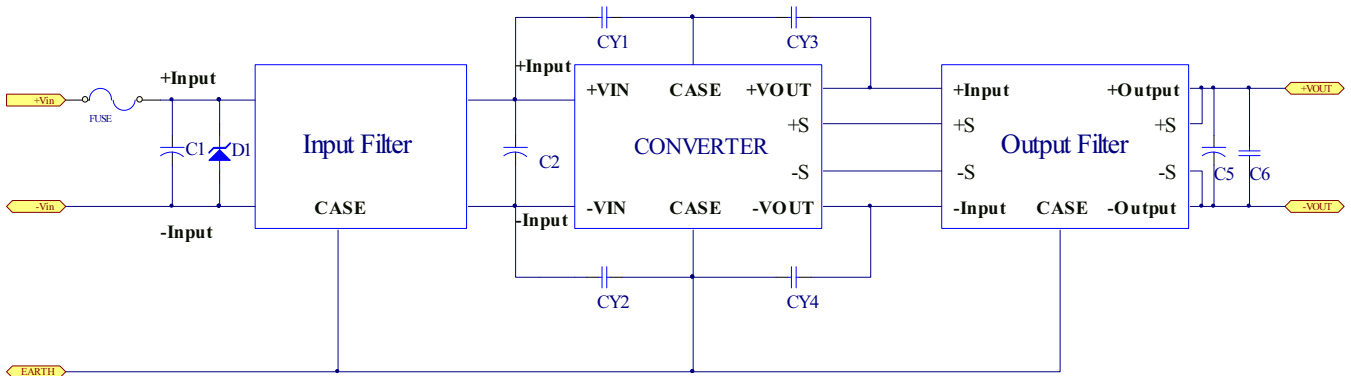

If the remote sense feature is not to be used, the sense pins should be connected locally. The +Sense pin should be connected to the +Vout pin at the module and the -Sense pin should be connected to the -Vout pin at the module. Wire between +Sense and +Vout and between -Sense and -Vout as short as possible. Loop wiring should be avoided. The converter might become unstable by noise coming from poor wiring. This is shown in the schematic below.

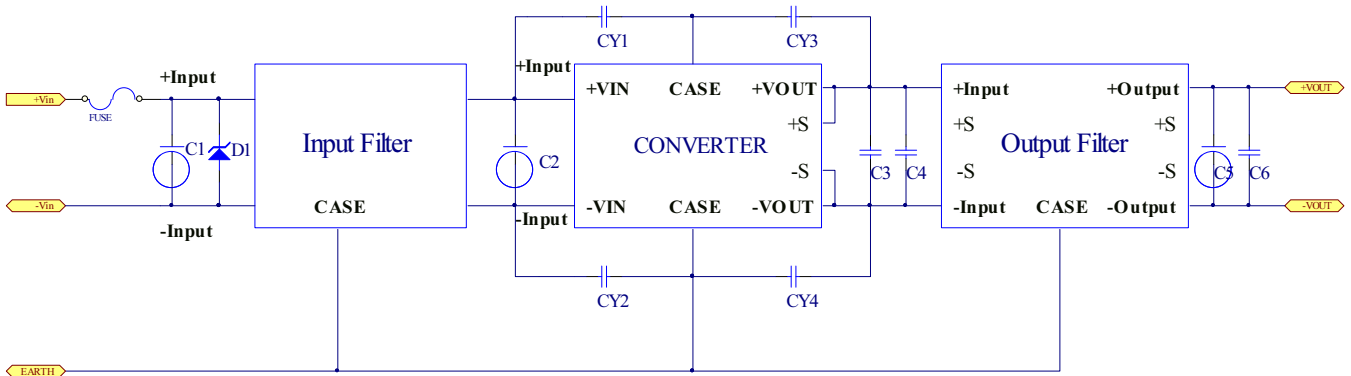



FM30R080P 30AMP DC FILTER MODULE

Application Note V11 May 2020

6.4 Power Derating

The operating case temperature range of FM30R080P is -40°C to +110°C. When operating the FM30R080P, proper derating or cooling is needed. The maximum case temperature under any operating condition should not exceed 110°C.

The following curve is the de-rating curve of FM30R080P without heat sink.

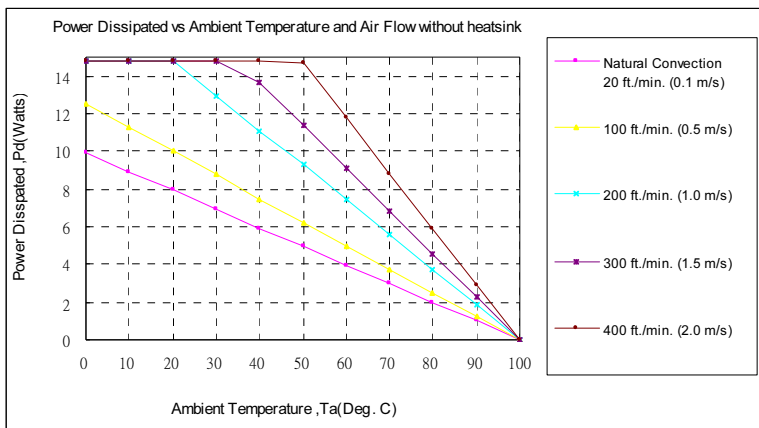

AIR FLOW RATE	TYPICAL R _{ca}
Natural Convection 20ft./min. (0.1m/s)	10.1 °C/W
100 ft./min. (0.5m/s)	8.0 °C/W
200 ft./min. (1.0m/s)	5.4 °C/W
300 ft./min. (1.5m/s)	4.4 °C/W
400 ft./min. (2.0m/s)	3.4 °C/W

Example:

What is the minimum airflow necessary for a FM30R080P operating at output current of 30A, and a maximum ambient temperature of 70°C?

Solution:

Given:

$$I_o = 30A$$

Determine Power dissipation (P_d):

$$P_d = I_o \times I_o \times DCR$$

$$P_d = 30A \times 30A \times (2m\Omega + 2m\Omega) = 3.6Watts$$

Determine airflow:

$$\text{Given: } P_d = 3.6W \text{ and } T_a = 70^\circ C$$

Check **Power Derating** curve:

$$\text{Minimum airflow} = 20 \text{ ft./min.}$$

Verify:

Maximum temperature rise is

$$\Delta T = P_d \times R_{ca} = 3.6W \times 10.1 = 36.36^\circ C$$

Maximum case temperature is

$$T_c = T_a + \Delta T = 106.36^\circ C < 110^\circ C$$

Where:

The R_{ca} is thermal resistance from case to ambient environment.

T_a is ambient temperature and T_c is case temperature.



FM30R080P 30AMP DC FILTER MODULE

Application Note V11 May 2020

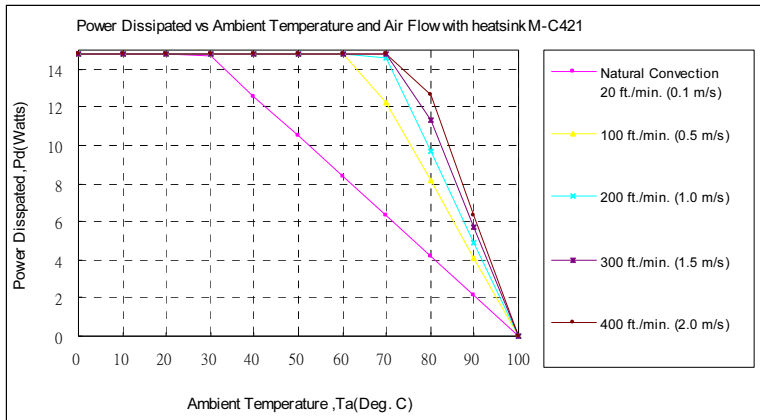

AIR FLOW RATE	TYPICAL R_{ca}
Natural Convection	4.78 °C/W
20ft./min. (0.1m/s)	4.78 °C/W
100 ft./min. (0.5m/s)	2.44 °C/W
200 ft./min. (1.0m/s)	2.06 °C/W
300 ft./min. (1.5m/s)	1.76 °C/W
400 ft./min. (2.0m/s)	1.58 °C/W

Example with heat sink QBT210 (M-C421):

What is the minimum airflow necessary for a FM30R080P operating at output current of 30A, and a maximum ambient temperature of 90°C?

Solution:

Given:

$$I_o = 5A$$

Determine Power dissipation (P_d):

$$P_d = I_o \times I_o \times DCR$$

$$P_d = 30A \times 30A \times (2m\Omega + 2m\Omega) = 3.6Watts$$

Determine airflow:

$$\text{Given: } P_d = 5.4W \text{ and } T_a = 90^\circ C$$

Check above Power de-rating curve:

$$\text{Minimum airflow} = 20 \text{ ft./min}$$

Verify:

$$\text{Maximum temperature rise is } \Delta T = P_d \times R_{ca} = 3.6 \times 4.78 = 17.21^\circ C$$

$$\text{Maximum case temperature is } T_c = T_a + \Delta T = 107.21^\circ C < 110^\circ C$$

Where:

The R_{ca} is thermal resistance from case to ambient environment.

T_a is ambient temperature and T_c is case temperature.



FM30R080P 30AMP DC FILTER MODULE

Application Note V11 May 2020

6.5 Quarter Brick Heat Sinks:

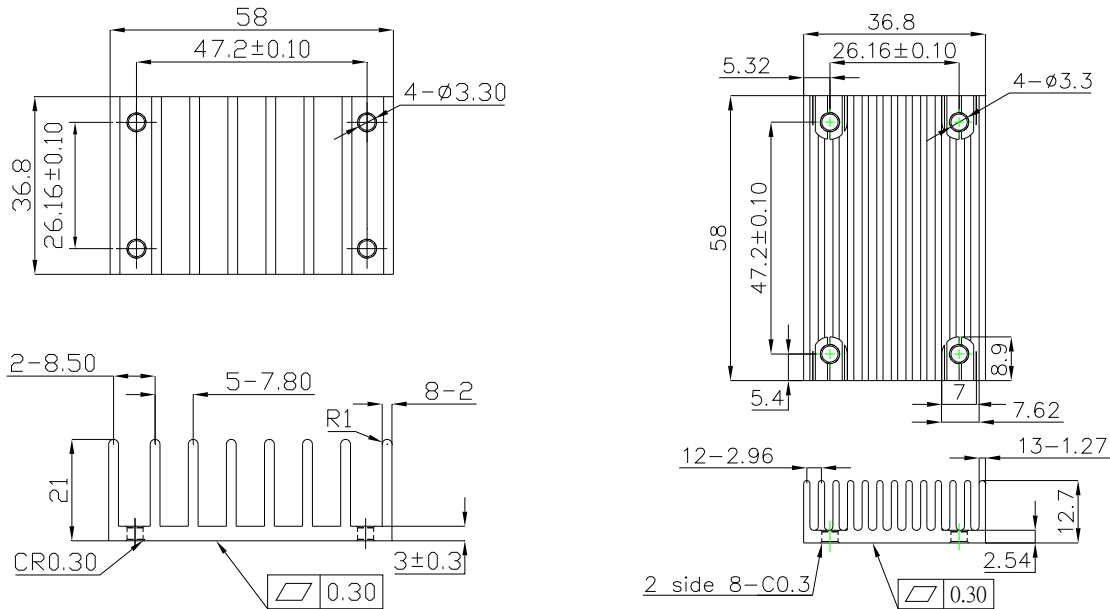

All Dimensions in mm

QBT210 (M-C421): G6620510201 Transverse Heat Sink

- Rca: 4.78°C/W (typ.), At natural convection
- 2.44°C/W (typ.), At 100LFM
- 2.06°C/W (typ.), At 200LFM
- 1.76°C/W (typ.), At 300LFM
- 1.58°C/W (typ.), At 400LFM

QBL127 (M-C448): G6620570202 Longitudinal Heat Sink

- Rca: 5.61°C/W (typ.), At natural convection
- 4.01°C/W (typ.), At 100LFM
- 3.39°C/W (typ.), At 200LFM
- 2.86°C/W (typ.), At 300LFM
- 2.49°C/W (typ.), At 400LFM

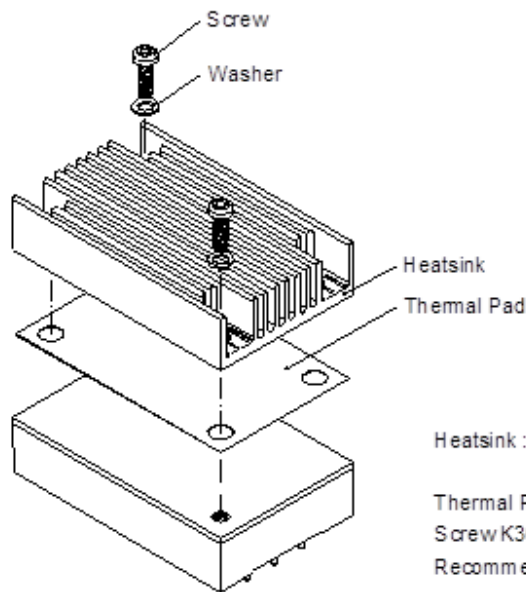

- Heatsink : QBL127 (M-C448)
- QBT210 (M-C421)
- Thermal Pad PQ01: SZ35.8x56.9x0.25mm
- Screw K308W: SMP+SW M 3x8L
- Recommended torque 3 Kg f-cm

Figure 4 Installation Drawing



FM30R080P 30AMP DC FILTER MODULE

Application Note V11 May 2020

7. Connection for Standard Use

7.1 Recommended Schematic

EMI performance is affected by a variety of external factors, such as PCB construction, circuit layout, and more. Therefore, in some applications, components other than filters may be required to fully comply with the specified standards. For railway application, the FM30R080P output filter is required for output conducted noise to meet EN50155: EN50121-3-2:2015.

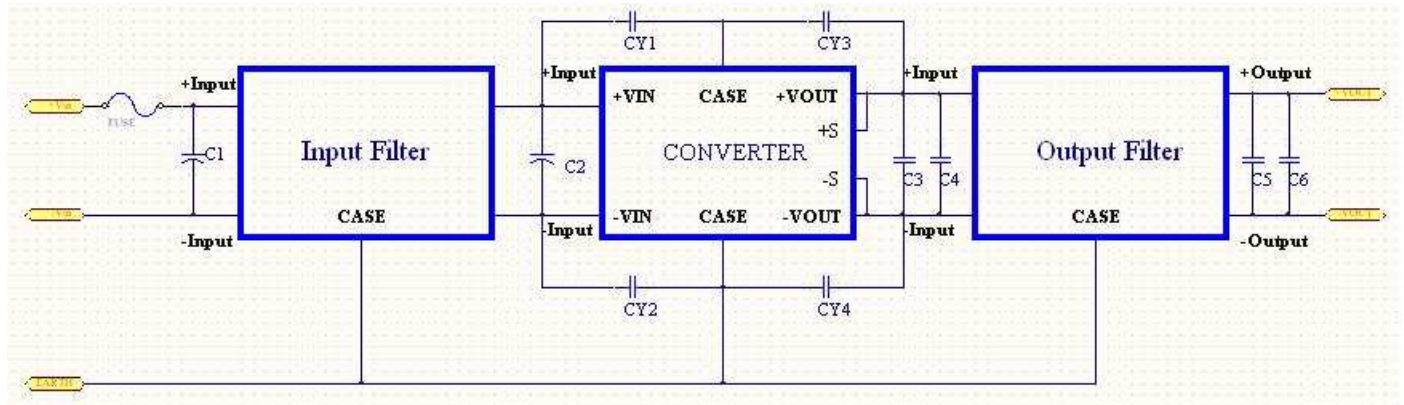

Note:

The FM05D200P, C1-C4 and CY1-CY4 are input conducted and radiated emission requirements.

CY1-CY4 Select the voltage rating to meet input-to-output isolation requirements.

C2 should be the recommended value indicated in the power module datasheet.

If the impedance of input line is high, Input capacitance must be more than above. Use more than two recommended capacitor above in parallel when ambient temperature becomes lower than -20 °C

7.2 EMC Considerations

EMI Test standard: EN50155 EN50121-3-2:2015 Output Conducted Emission

Test Condition: Input Voltage: Nominal, Output Load: Full Load

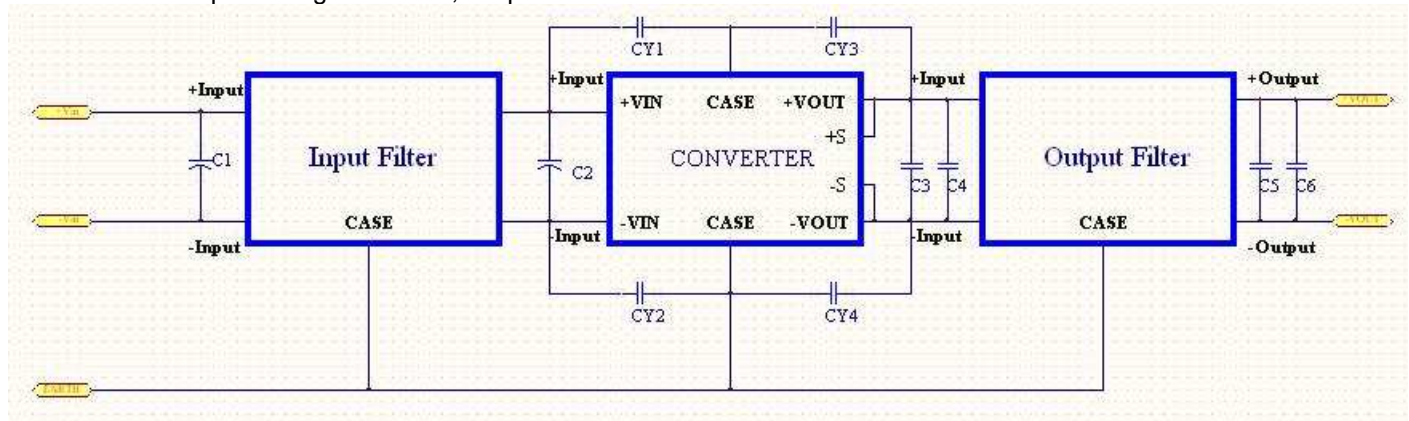

Figure1 Connection circuit for conducted testing



FM30R080P 30AMP DC FILTER MODULE

Application Note V11 May 2020

Input Filter Module	DC-DC Converter Model No.	Output Filter Module	C1	C2	C3	C4	CY1	CY2	CY3	CY4
FM05D200P	CQB150W-110S3V3 CQB150W-110S05 CQB150W-110S15 CQB150W-110S48 CQB100W-110S05 CQB100W-110S15 CQB100W-110S48	FM30R080P	220uF	220uF	10uF	1uF	2200pF	2200pF	1000pF	1000pF
	1500pF						1500pF	680pF	680pF	

Note: The FM05D200P, C1-C4 and CY1-CY4 are input conducted and radiated emission requirements

C1, C2 are CHEMICON 220uF/200V KXJ series aluminum capacitors,

C3, C4 are ceramic capacitor

CY1, CY2, CY3, CY4 are TDK Y1 capacitors or equivalent.

Bead Core SN030 T2.8*1.7*1.2 SM for CY1, CY2.

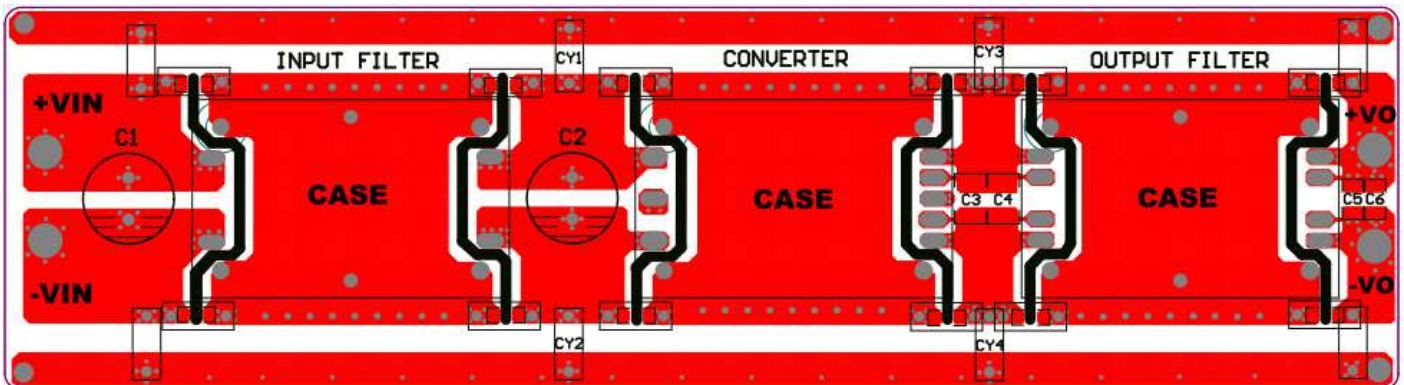

EMI test board top side

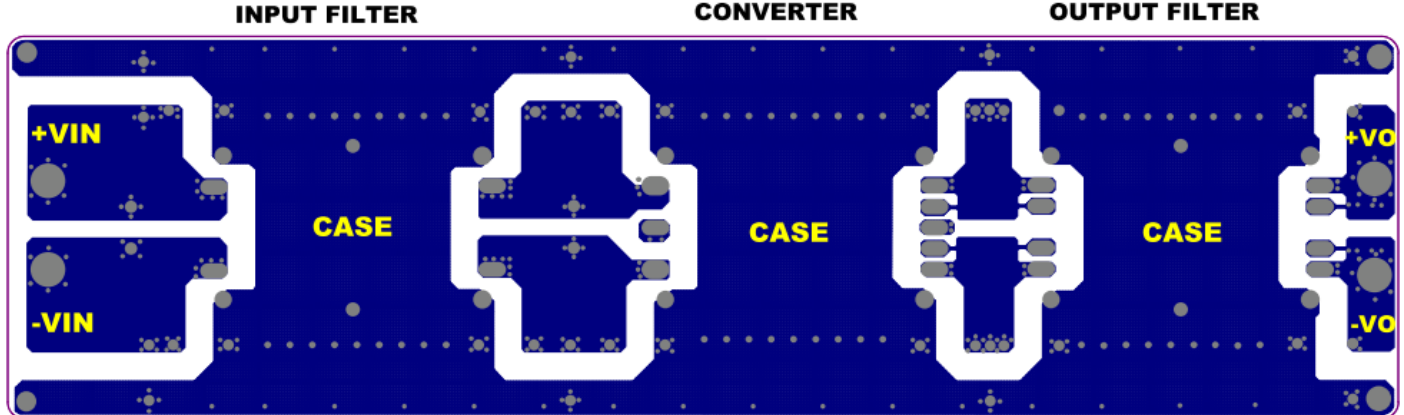

EMI test board bottom side



FM30R080P 30AMP DC FILTER MODULE

Application Note V11 May 2020

(1) The CQB150W-110SXX Series output conducted noise to meet EN50155: EN50121-3-2:2015 required:

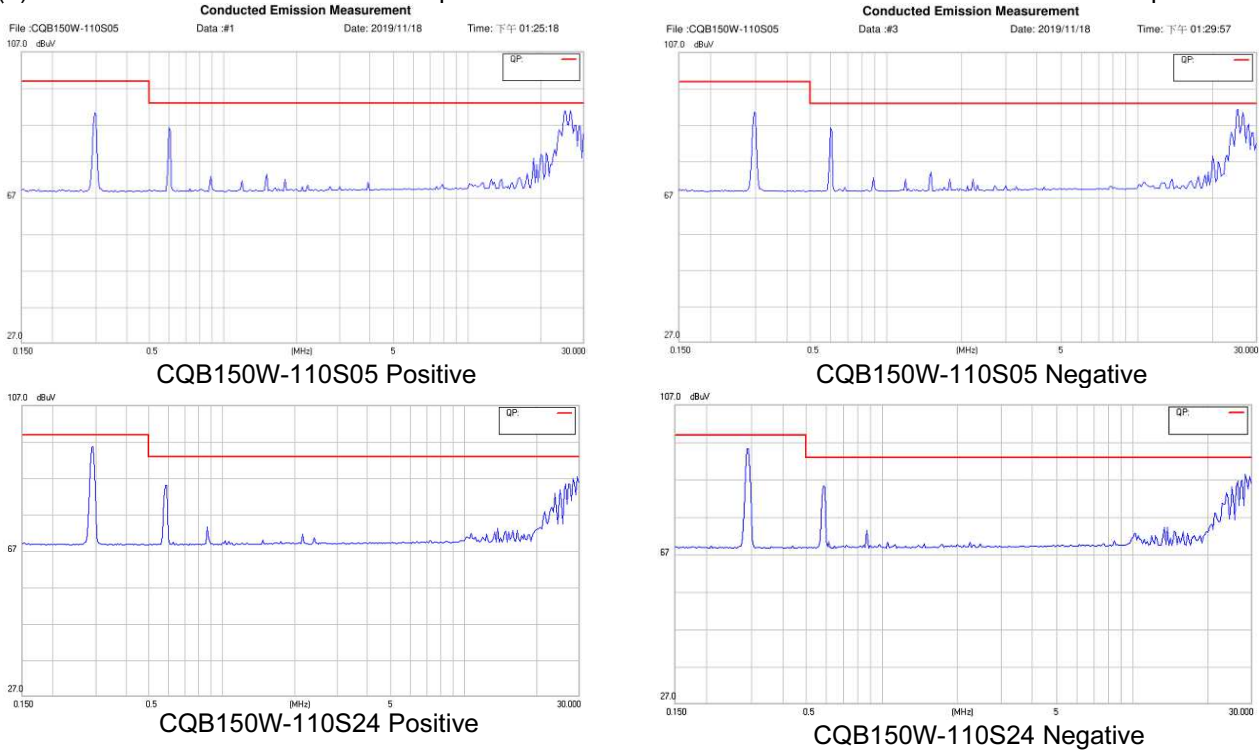

(2) The CQB150W-24SXX and 48SXX Series output conducted noise to meet EN50155: EN50121-3-2:2015 required:

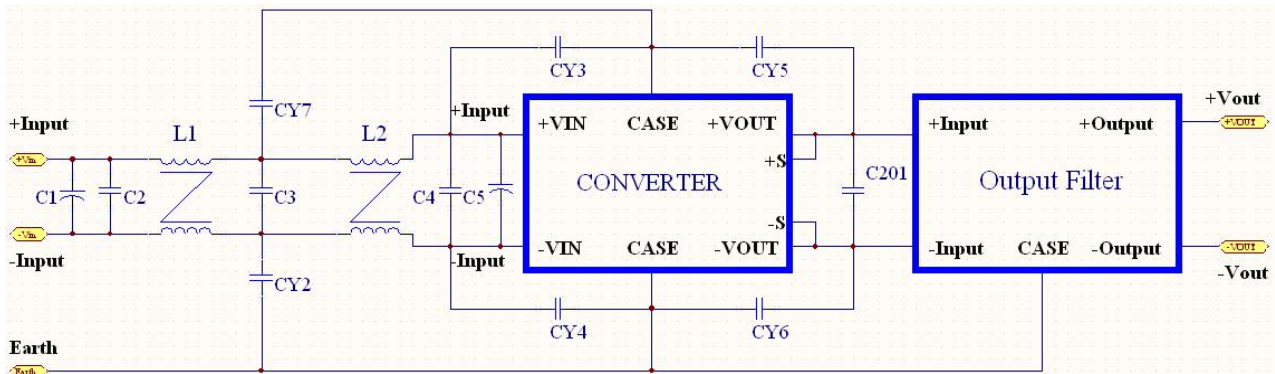

Model No.	L1, L2	C1, C5	C2	C3	C4	C201	CY2	CY3	CY4	CY5	CY6	CY7
CQB150W-24SXX	1mH	470uF/50V	6.8uF/50V			NC	2200pF	3300pF	3300pF	2200pF	3300pF	2200pF
CQB150W-48SXX	1mH	150uF/100V	4.7uF/100V	1uF/100V			3300pF	3300pF	3300pF	1000pF	2200pF	3300pF

Note: The above recommended parts are input conducted and radiated emission requirements

C2, C3, C4, C201 is ceramic capacitors.

C1, C5: NIPPON CHEMI-CON KY Series or RUBYCON ZLH Series or equivalent.

CY2~CY7: TDK CD SERIES

L1, L2: SC-10-10J (TOKIN) or equivalent.

OUTPUT FILTER: **FM30R080P** CINCON



FM30R080P 30AMP DC FILTER MODULE

Application Note V11 May 2020

EMI test board top side

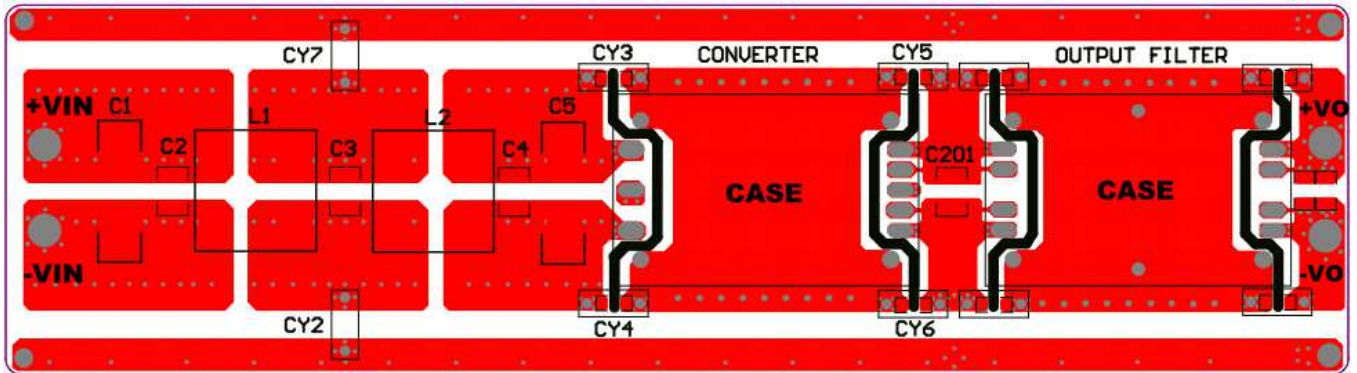

CONVERTER

OUTPUT FILTER

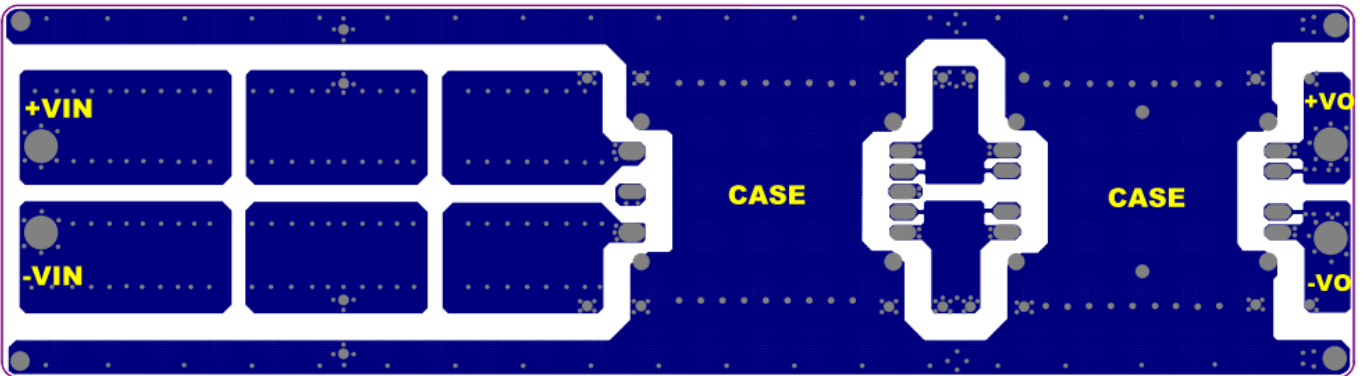

EMI test board bottom side

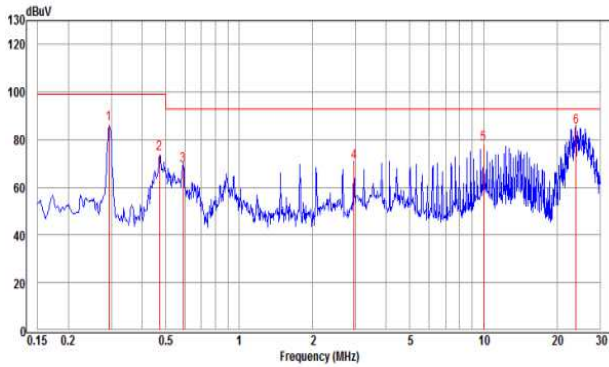

CQB150W-24S24 Positive

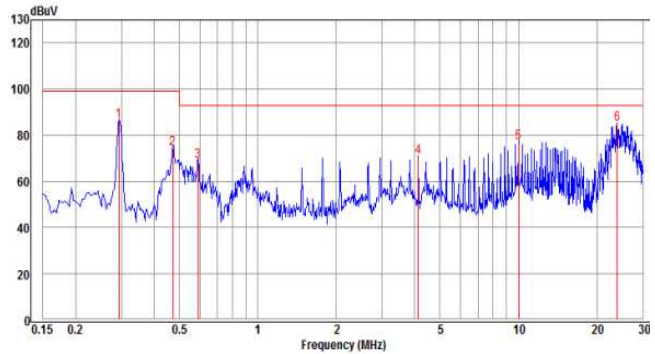

CQB150W-24S24 Negative

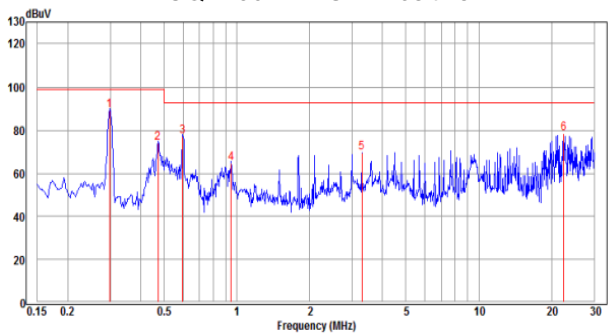

CQB150W-48S24 Positive

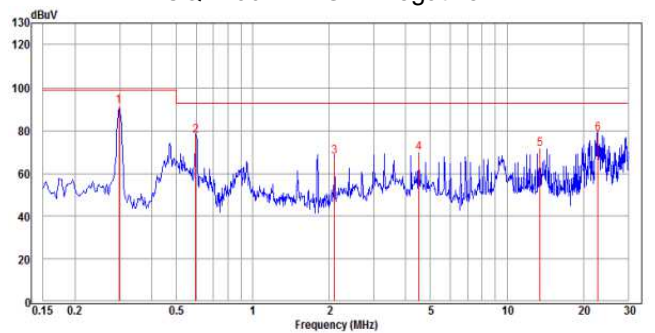

CQB150W-48S24 Negative



FM30R080P 30AMP DC FILTER MODULE

Application Note V11 May 2020

(3) The CQB150W-110SXX-CMFC(D) output conducted noise meet EN50155 : EN50121-3-2:2015 required:

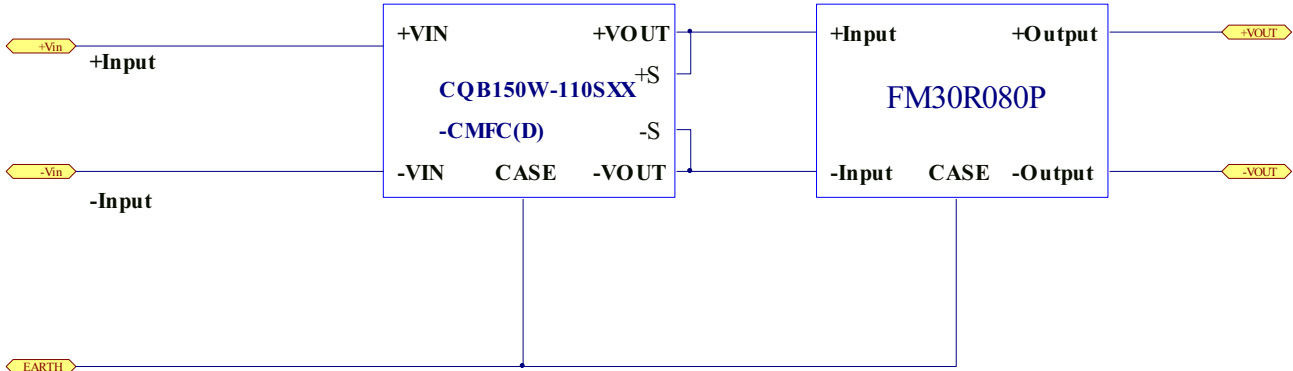

Connection circuit for CQB150W-110SXX-CMFC(D)

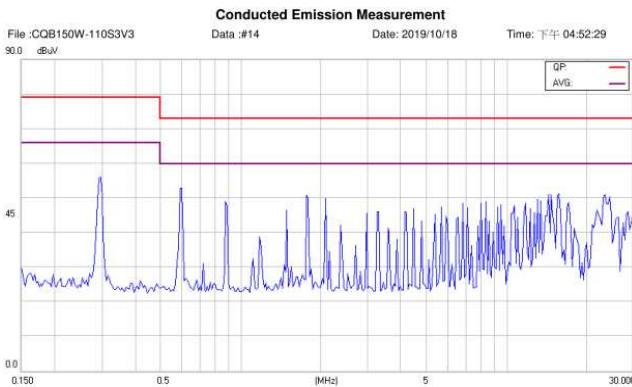

CQB150W-110S3V3-CMFC(D) Positive

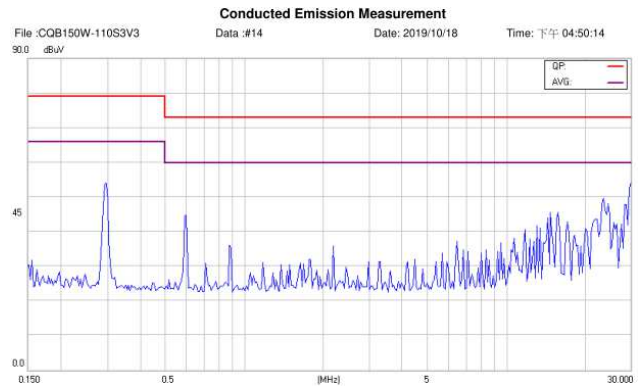

CQB150W-110S3V3-CMFC(D) Negative

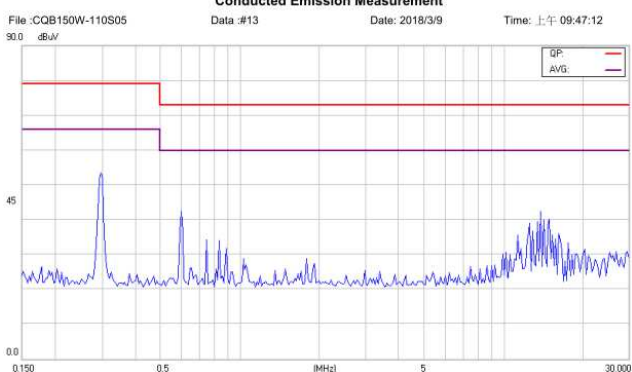

CQB150W-110S05-CMFC(D) Positive

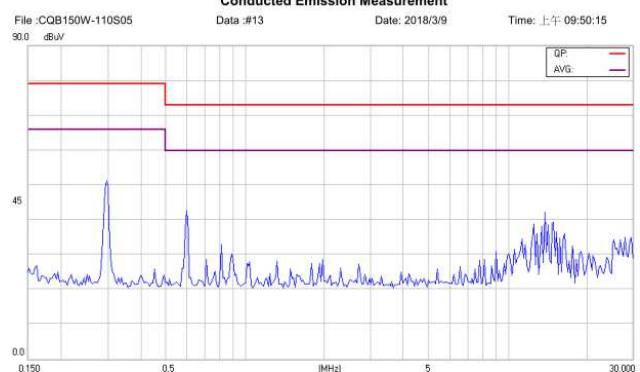

CQB150W-110S05-CMFC(D) Negative



FM30R080P 30AMP DC FILTER MODULE

Application Note V11 May 2020

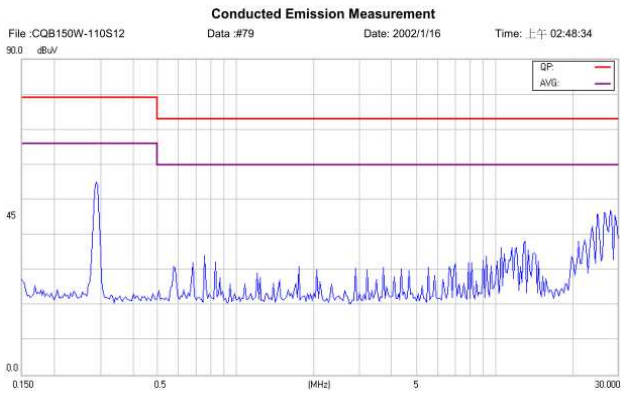

CQB150W-110S12-CMFC(D) Positive

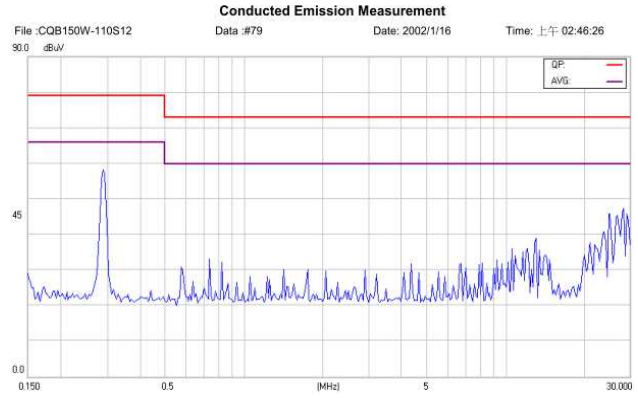

CQB150W-110S12-CMFC(D) Negative

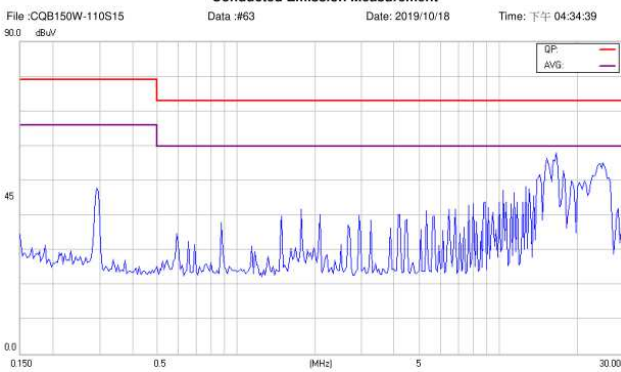

CQB150W-110S15-CMFC(D) Positive

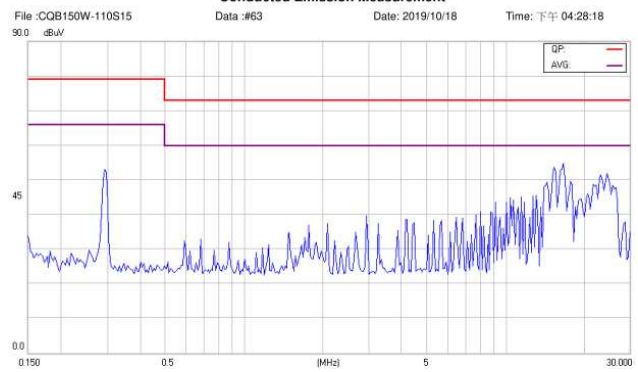

CQB150W-110S15-CMFC(D) Negative

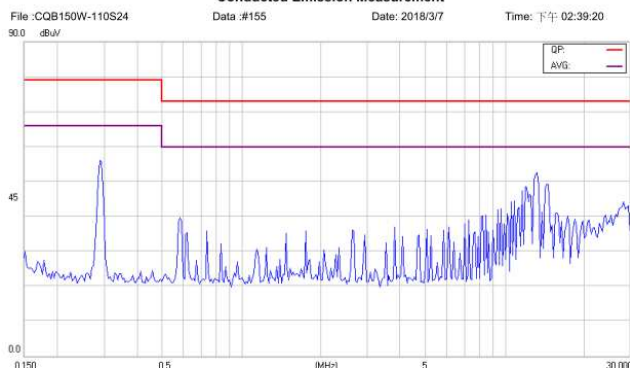

CQB150W-110S24-CMFC(D) Positive

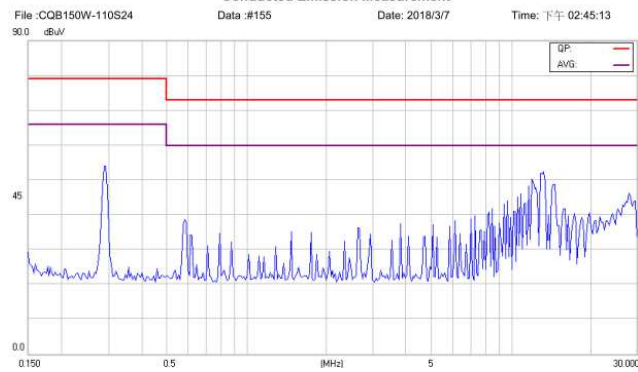

CQB150W-110S24-CMFC(D) Negative

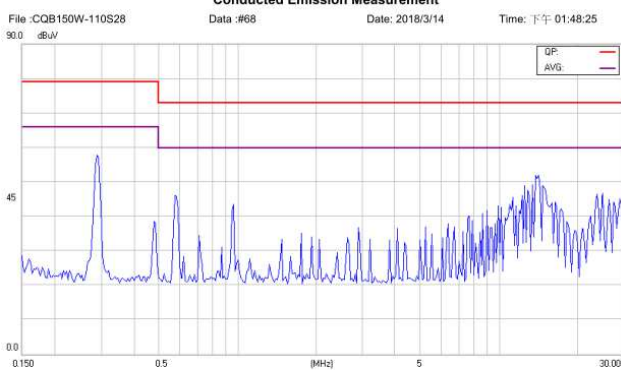

CQB150W-110S28-CMFC(D) Positive

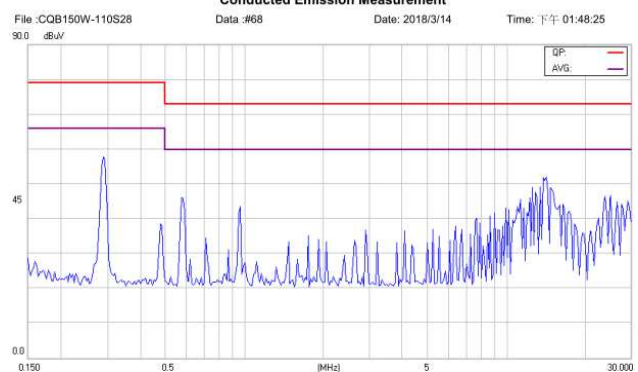

CQB150W-110S28-CMFC(D) Negative



FM30R080P 30AMP DC FILTER MODULE

Application Note V11 May 2020

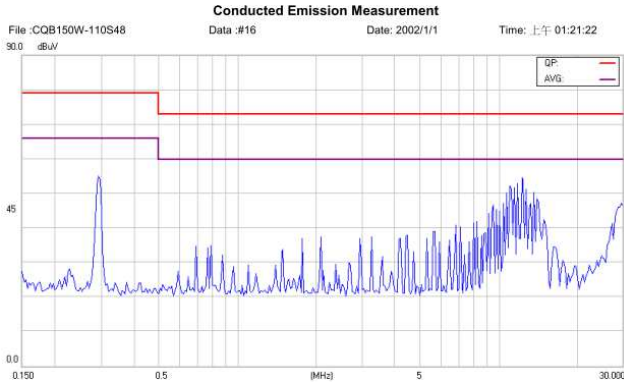

CQB150W-110S48-CMFC(D) Positive

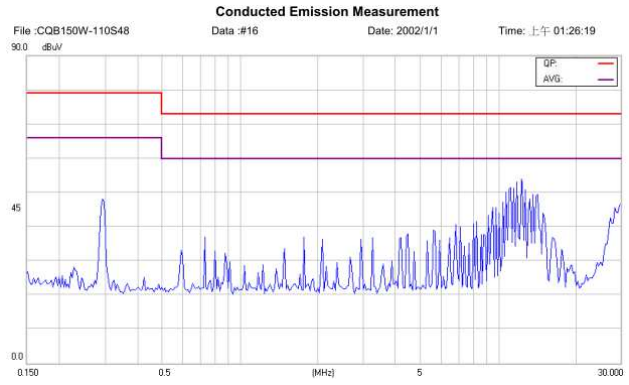

CQB150W-110S48-CMFC(D) Negative



FM30R080P 30AMP DC FILTER MODULE

Application Note V11 May 2020

8. Part Number

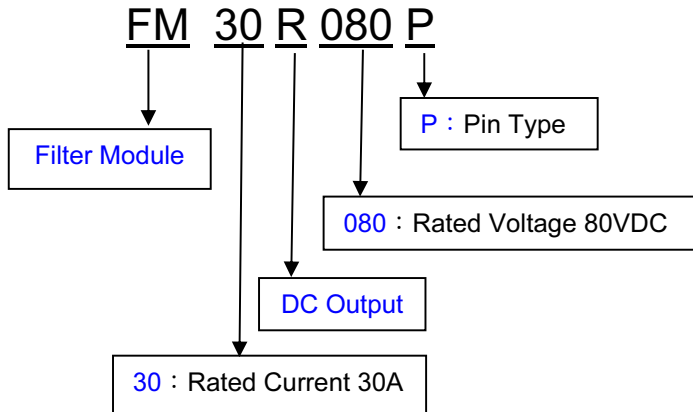

9. Mechanical Outline Diagrams

9.1 FM30R080P Mechanical Outline Diagrams

All Dimensions In Inches[mm]

Tolerance Inches:x.xx= ±0.02, x.xxx= ±0.010

Millimeters:x.x= ±0.5, x.xx=±0.25

BOTTOM VIEW

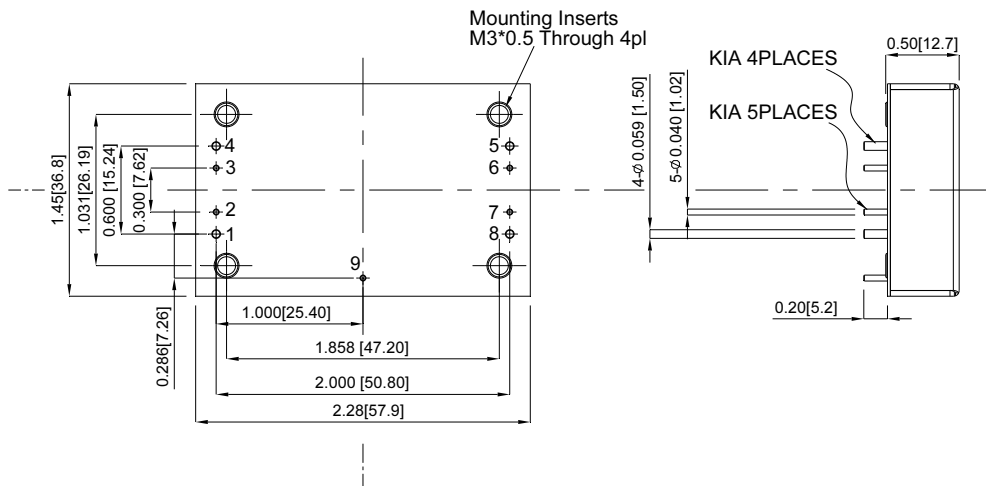

PIN CONNECTION	
PIN	Function
1	+V Input
2,7	+Sense
3,6	-Sense
4	-V Input
5	-V Output
8	+V Output
9	Case

CINCON ELECTRONICS CO., LTD.

Headquarters:

14F, No.306, Sec.4, Hsin Yi Rd.
 Taipei, Taiwan
 Tel: 886-2-27086210
 Fax: 886-2-27029852
 E-mail: support@cincon.com.tw
 Web Site: <http://www.cincon.com>

Factory:

No. 8-1, Fu Kung Rd.
 Fu Hsing Industrial Park
 Fu Hsing Hsiang,
 Chang Hua Hsien, Taiwan
 Tel: 886-4-7690261
 Fax: 886-4-7698031

Cincon North America:

1655 Mesa Verde Ave. Ste 180
 Ventura, CA 93003
 Tel: 805-639-3350
 Fax: 805-639-4101
 E-mail: info@cincon.com