

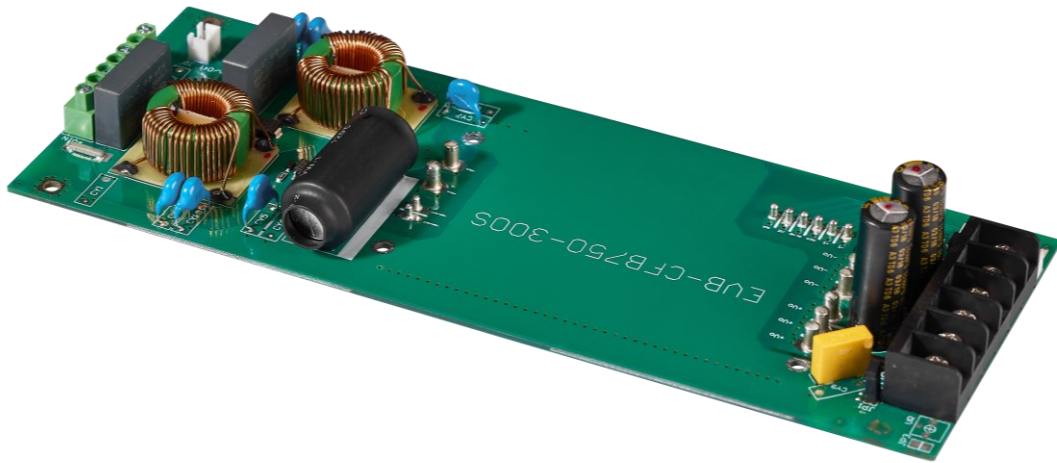

EVB-CFB750-300S Series Application Note V11

Evaluation Board for CFB750-300S Series APPLICATION NOTE



Approved By:

Department	Approved By	Checked By	Written By
Research and Development Department	Jacky	Astray	Jiawei
Design Quality Department	Benny	JoJo	



EVB-CFB750-300S Series Application Note V11

Contents

1. Introduction	3
2. Pin Function Description Input and Output Connections.....	3
3. Output Remote Sense, Trim Resistors.....	4
3.1 Output Remote Sensing	4
3.2 Output Voltage Adjustment.....	4
4. Schematic	5
5. Component Placement.....	5
6. Bill of Materials (BOM)	7



EVB-CFB750-300S Series Application Note V11

1. Introduction

The EVB-CFB750-300S is the evaluation board for testing CFB750-300S series. It has a (2:1) input voltage range of 200 to 425VDC. For help in testing the performance of DC-DC converters, please refer to the [CFB750-300S application note](#).

Shock Warning:

Certain areas of the evaluation board are exposed to high voltage. Be careful to avoid contact with these voltages. After disconnecting the input power, the evaluation board may temporarily maintain high voltage. Be careful when handling.

Application of Input Power:

The evaluation board **prohibits hot plugging**, So **don't use** a knife switch or circuit breaker to connect the input power. This type of action applies the input voltage at an uncontrolled very high rate of rise (dV/dt), which may damage the converter and external components before the converter. The input voltage should be applied at a controlled rate of rise (recommend 10V/uS). Also, before inserting or removing the converter module from the evaluation board, make sure that the input voltage is turned off.

Thermal Considerations:

When testing the converter on the evaluation board, ensure adequate cooling. Use a fan to blow the cooling air so that the fan blows through the converter or the radiator connected to the converter. The converter temperature to ensure that it does not exceed the maximum rated temperature specified in the data sheet.

Sockets of DC DC Converter:

The evaluation board uses sockets to provide options for testing different converters. These sockets are not suitable for continuous high current. Short-term testing is possible, but please be aware of this limitation of long-term testing. The socket will add resistance in the power loop, which will cause a voltage drop at higher currents, which can cause significant errors in regulation and efficiency measurements. These socket also do not provide a thermal cooling path from the module pins to the PCB wiring, which may cause higher converter temperatures and errors when performing thermal evaluation. For long-term testing, thermal testing and permanent installation, it is recommended to use soldered connections.

2. Pin Function Description Input and Output Connections

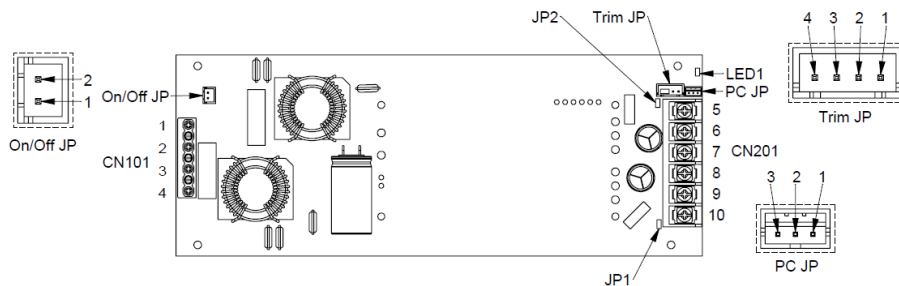

No	CN101&CN201	Description	No	Trim JP	Description
1	Case	Connected to DC Module Case	1	-Sense	Negative Output Remote Sense
2	+Remote	External Remote On/Off Control	2	+Sense	Positive Output Remote Sense
3	-V Input	Negative Supply Input	3	Trim	External Trim Adjustment
4	+V Input	Positive Supply Input	4	Rt	External Rt Adjustment
5	-V Output	Negative Power Output	No	On/Off JP	Description
6	-V Output	Negative Power Output	1	+Remote On/Off	External Remote On/Off Control
7	-V Output	Negative Power Output	2	-Remote On/Off	Connected to Negative Supply Input
8	+V Output	Positive Power Output	No	PC JP	Description
9	+V Output	Positive Power Output	1	AUX	Auxiliary Power for Output
10	+V Output	Positive Power Output	2	IOG	Inverter Operation Good Signal
			3	PC	Parallel Operation Control

Note: DC module Case can be connected to PCB through M3 threaded mounting insert. Recommended torque 3Kgf-cm.



EVB-CFB750-300S Series

Application Note V11

3. Output Remote Sense, Trim Resistors

3.1 Output Remote Sensing

The CFB750-300S series converter has the capability to remotely sense both lines of its output. This feature moves the effective output voltage regulation point from the output of the unit to the point of connection of the remote sense pins. This feature automatically adjusts the real output voltage of the EVB- CFB750-300S series in order to compensate for voltage drops in distribution and maintain a regulated voltage at the point of load. The remote-sense voltage range please refer to the [CFB750-300S application note](#).

When remote sensing is used, please remove the jumper of JP1 and JP2 and the sense should be connected by twisted-pair wire or shield wire. If the sensing patterns short, heavy current flows and the pattern may be damaged. Output voltage might become unstable because of impedance of wiring and load condition when length of wire is exceeding 400mm. This is shown in the schematic below.

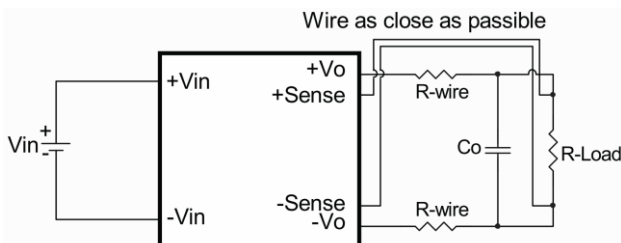

When the EVB-CFB750-300S was shipped from a factory, they come with JP1 and JP2 placed on PCB. If the remote sense feature is not to be used, the sense JP1 and JP2 should be connected locally.

Note:

Although the output voltage can be varied (increased or decreased) by both remote sense and trim, the maximum variation for the output voltage is the larger of the two values not the sum of the values. The output power delivered by the module is defined as the voltage at the output terminals multiplied by the output current. Using remote sense and trim can cause the output voltage to increase and consequently increase the power output of the module if output current remains unchanged. Always ensure that the output power of the module remains at or below the maximum rated power. Also be aware that if V_{o_set} is below nominal value, P_{out_max} will also decrease accordingly because I_{o_max} is an absolute limit. Thus, $P_{out_max} = V_{o_set} \times I_{o_max}$ is also an absolute limit.

3.2 Output Voltage Adjustment

EVB-CFB750-300S is shipped without trim resistor for output voltage adjustment, output voltage can be adjusted by external variable resistor (adjustment range: please refer to the [CFB750-300S application note](#)).

Note: Description of Trim Resistors

The trim resistors R_t , R_3 and V_R are not populated in this evaluation board. This is to allow the user to determine and install the needed trim resistance values based on the range of desired output voltage adjustment of the module being evaluated.



EVB-CFB750-300S Series Application Note V11

4. Schematic

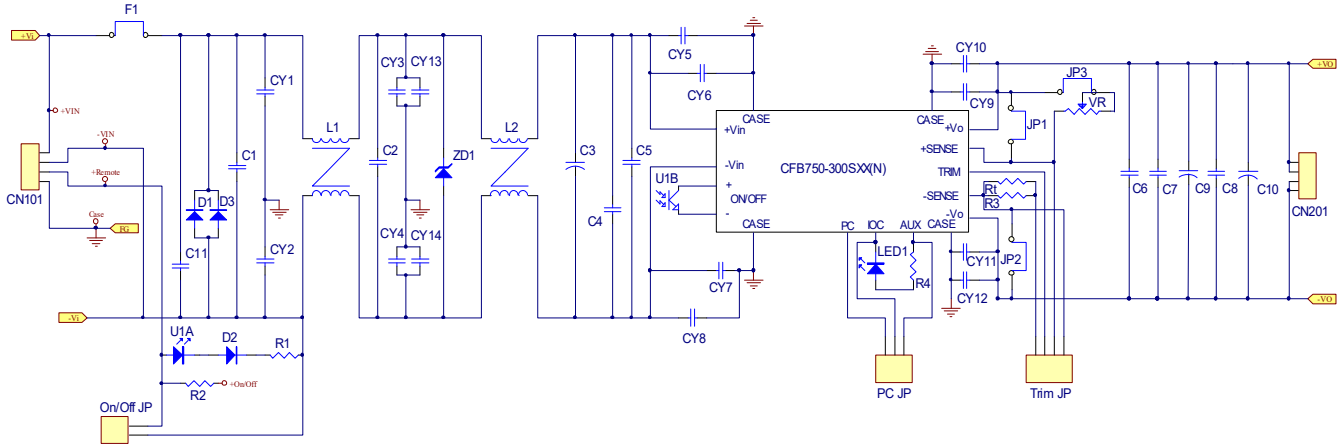

Figure1 Schematic

5. Component Placement

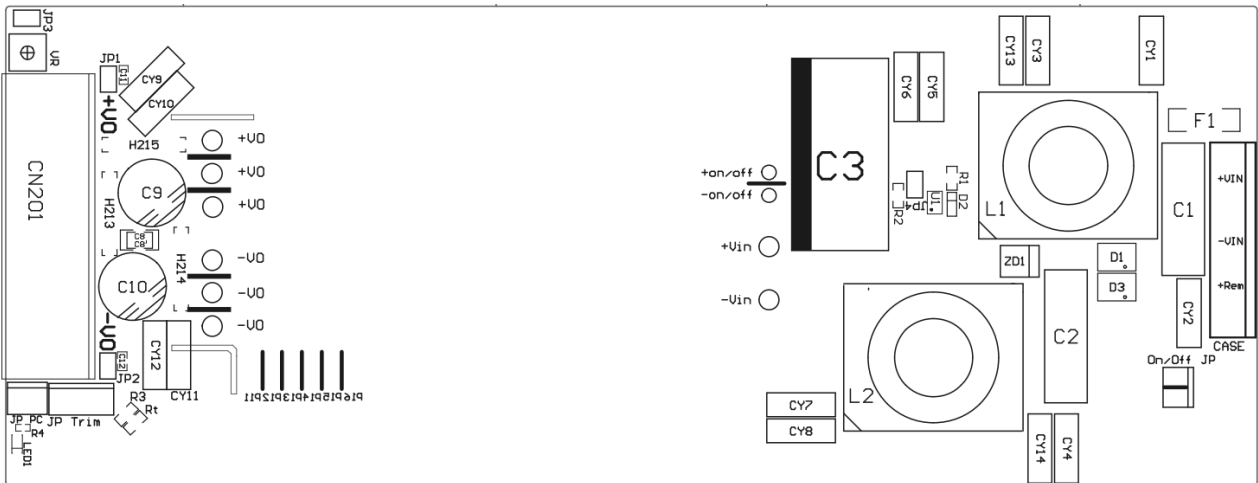

Figure2 Component Placement

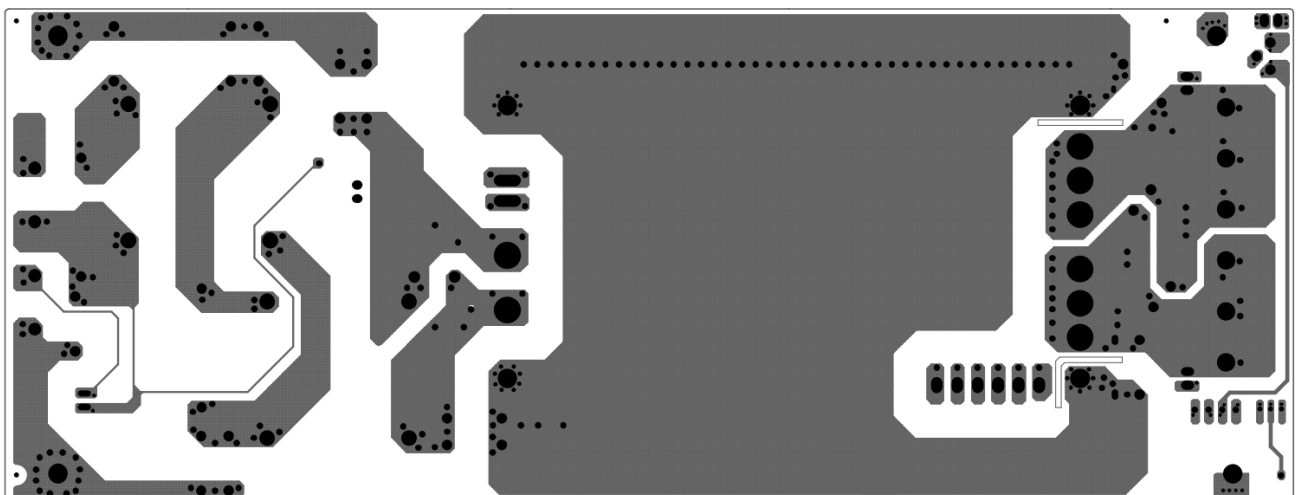

Figure3 PCB Layout Top View



EVB-CFB750-300S Series Application Note V11

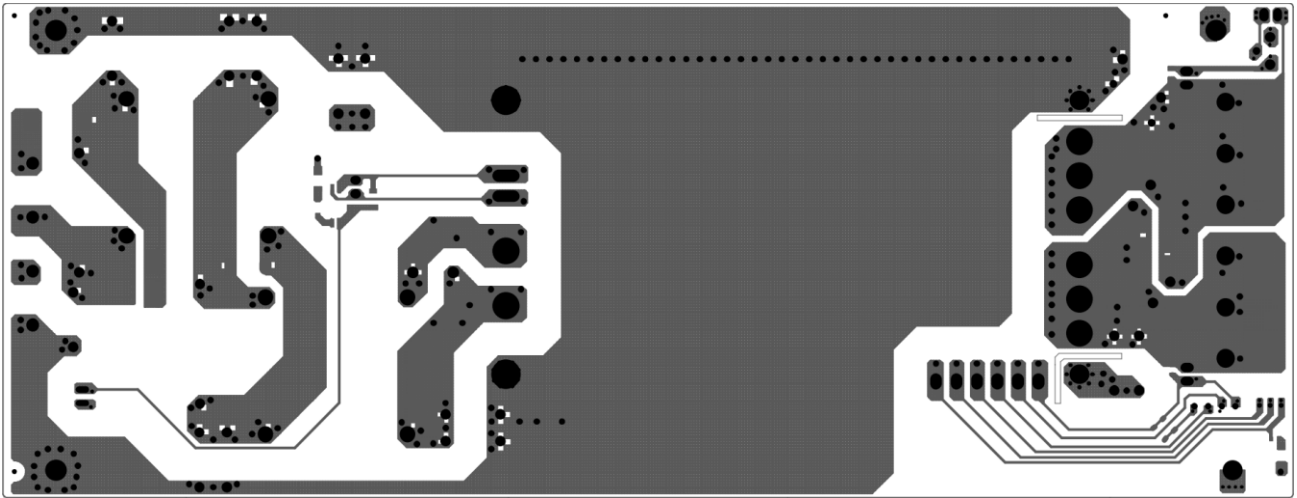

Figure4 PCB Layout Bottom View



EVB-CFB750-300S Series Application Note V11

6. Bill of Materials (BOM)

Components value:

Designator	Description	Value	Comment
C1, C2	X2 CAP.	0.68uF/305VAC	MKP-684K0305AB1221 or equivalent
C3	ALUMINUM CAP.	120uF/450VDC	450BXW120MEFR 18X35 or equivalent
C9, C10	ALUMINUM CAP.	820uF/63VDC	KTC827M063S1G6K356 or equivalent
CY3, CY4, CY5, CY7	Y1 CAP.	2200pF/400VAC	CD90ZU2GA222MYNKA or equivalent
CY10, CY11	X2 CAP.	0.022uF/275VAC	PX223K31C29L200D9R or equivalent
CY13, CY14	Y1 CAP.	470pF/400VAC	CD85-B2GA471KYNKA or equivalent
L1, L2	Common choke DIP	3.101~5.395mH.	CINCON Part Number: G91C3825015
JP1, JP2	Single Row Header.	2.54mm Pitch.	P301G-02-G1 or equivalent
CN101	TERMINAL BLOCK	600V, 12A.	166-04P5 DINKLE or equivalent
CN201	TERMINAL BLOCK	300V, 25A.	DT-49-B01W-06 DINKLE or equivalent
Trim JP	WAFER DIP	2.5mm Pitch.	JS-1001-04(K) or equivalent
PC JP	WAFER DIP	2mm Pitch.	B3B-PH-K-S(LF)(SN) or equivalent
ON/OFF JP.	WAFER DIP	2.5mm Pitch.	8822-02 or equivalent.
MINI JUMPER (Trim JP, PC JP, ON/OFF JP)	MINI JUMPER	2.54mm Pitch.	HMJ254-02C-65B or equivalent
R1	CHIP RESISTOR	1/4W 4.7K	SMD 1206.
R4	CHIP RESISTOR	1/10W 47K	SMD 0603.
C8	CHIP CAP.	4.7uF/100V X7R	SMD 1812.
D1, D3	ULTRAFast DIODE	600V, 5A	STTH5R06DJF-TR or equivalent
D2	DIODE	250V, 200mA	BAV21W or equivalent
LED1	LED	GREEN	MS-PT3216ZGSC or equivalent
ZD1	TVS	1500W 517.5V	SMCJ440A or equivalent.
U1	PHOTO COUPLER	SMD 4PIN SO4	TLP291 GRH, TOSHIBA or equivalent
P1, P2, P5, P6, P7, P8, P9, P10	SOCKET	2mm	3967TLG or equivalent
P3, P4, P11, P12, P13, P14, P15, P16	SOCKET	1mm	1726TLG or equivalent

Note: Other unmarked parts are not installed.

CINCON ELECTRONICS CO., LTD.

Headquarters:

14F, No.306, Sec.4, Hsin Yi Rd.
Taipei, Taiwan
Tel: 886-2-27086210
Fax: 886-2-27029852
E-mail: sales@cincon.com
Web Site: <https://www.cincon.com>

Factory:

No. 8-1, Fu Kung Rd.
Fu Hsing Industrial Park
Fu Hsing Hsiang,
ChangHua Hsien, Taiwan
Tel: 886-4-7690261
Fax: 886-4-7698031

Cincon North America:

1655Mesa Verde Ave. Ste 180
Ventura, CA93003
Tel: 805-639-3350
Fax: 805-639-4101
E-mail: info@cincon.com