



SIPSMT16W-12 SERIES

16 AMP

POL CONVERTERS



FEATURES

- * Non-Isolated POL Converter
- * SIP/SMT Package
- * Output Current 16AMP
- * Input Voltage Range 6.0 –14VDC
- * Output Voltage Range 0.7525–5.0VDC
- * 300KHz Switching Frequency
- * High Efficiency to 94%
- * Over Temperature Protection
- * Continuous Short Circuit Protection
- * Remote On/Off Control
- * Output Voltage Sequencing
- * Power Good Signal
- * UL/C-UL60950 Certified
- * Safety Meets IEC/EN/UL 62368-1

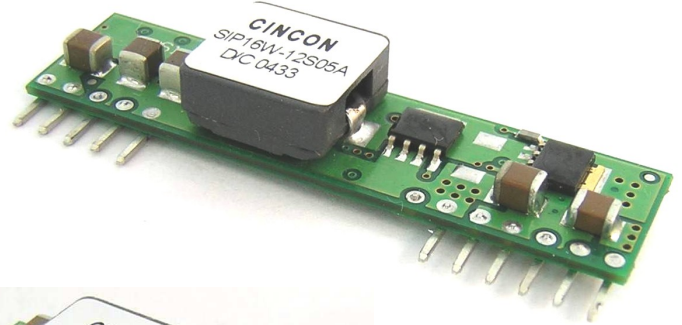

MODEL NUMBER	INPUT VOLTAGE	OUTPUT VOLTAGE	OUTPUT CURRENT	INPUT CURRENT		Efficiency (%)
				NO LOAD	FULL LOAD	
SIP16W-12S05A SMT16W-12S05A	6.0 – 14VDC	0.7525VDC	16A	40mA	1250mA	80
		1.2VDC	16A	40mA	1882mA	85
		1.5VDC	16A	50mA	2273mA	88
		1.8VDC	16A	60mA	2697mA	89
		2.0VDC	16A	60mA	2963mA	90
		2.5VDC	16A	65mA	3663mA	91
		3.3VDC	16A	75mA	4731mA	93
	6.5 – 14VDC	5.0VDC	16A	95mA	7092mA	94

NOTE: Nominal Input Voltage 12VDC

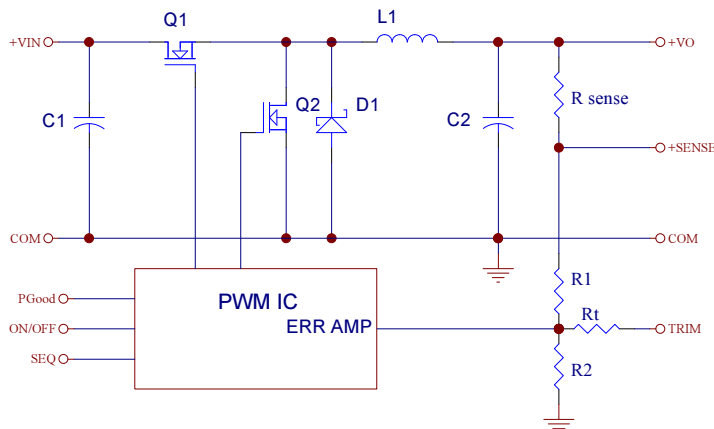

Vo,set (V)	Rtrim (KΩ)
0.7525	Open
1.2	22.46
1.5	13.05
1.8	9.024
2.0	7.417
2.5	5.009
3.3	3.122
5.0	1.472

Table 1. External Resistor Values for programming output voltage

Figure 1. Simplified Schematic

SPECIFICATIONS

All Specifications Typical at Nominal Line, Full Load, and 25°C Unless Otherwise Noted

INPUT SPECIFICATIONS:

Input Voltage Range..... 12V 6.0 – 14.0V
 12V 6.5 – 14.0V
 Under Voltage Lock-out power up 5.0V typ.
 power down 4.0V typ.
 Input Filter Type Capacitive
 Positive Remote On/Off Control:
 Module On Open Circuit or = Vin
 Module Off 0 to < 0.4 Vdc

OUTPUT SPECIFICATIONS:

Voltage Accuracy ±1.5% max.
 Transient Response: 25% Step Load Change <200µs
 Ripple and Noise, 20MHz BW (note3) 30mV rms max.
 75mV pk-pk max.
 Temperature Coefficient ±0.03%/C max.
 Short Circuit Protection Continuous
 Line Regulation (note1) ±0.2% max.
 Load Regulation (note2) ±0.5% max.
 External Trim Adj. Range (See Table1) Vo=0.75 – 5.0Vdc
 Sequencing Slew Rate Capability (dV_{SEQ}/dt) 0.1 – 1.0V/msec
 Sequencing Delay Time 10msec min.
 Tracking Accuracy .. Power up:200mV max., Power down:400mV max.
 Capacitive Load Low ESR 8000µF max.
 Power Good Signal Asserted Logic High Vo=90%-110%Vo, nom.
 Start up Time 7ms typ.

GENERAL SPECIFICATIONS:

Efficiency See Table
 Isolation Voltage Non-Isolation
 Switching Frequency 300KHz typ.
 Over Temperature Protection 130°C typ.
 Operating Ambient Temperature Range -40°C to +85°C
 Power Derating Curve See Figure2, 3
 Storage Temperature Range -55°C to +125°C
 MTBF MIL-HDBK-217F, GB, 25°C, Full Load 0.92Mhrs typ.

Dimensions:

SIP Package: 2 x 0.51 x 0.327 inches (50.8 x 12.95 x 8.3 mm)
 SMT Package: 1.3 x 0.53 x 0.346 inches (33.0 x 13.46x 8.8 mm)

Structure Non-Potted with Open Frame Type
 Weight 8.5g

NOTE:

1. Measured from high line to low line, Vo,set=3.3Vdc.
2. Measured from full load to zero load, Vo,set=3.3Vdc.
3. The output noise is measured with 10µF tantalum capacitor and 1µF ceramic capacitor across output.
4. The input terminal recommend to parallel with 100µF capacitor ESR<100mΩ to Reduce the input ripple voltage.
5. Suffix "N" to the model number with negative logic remote on/off
 Model on Open Circuit or 0 to < 0.4Vdc
 Module off >+2.8VDC to Vin
6. Suffix "P" to the model number with power good function.

Dimensions:

SIP Packages

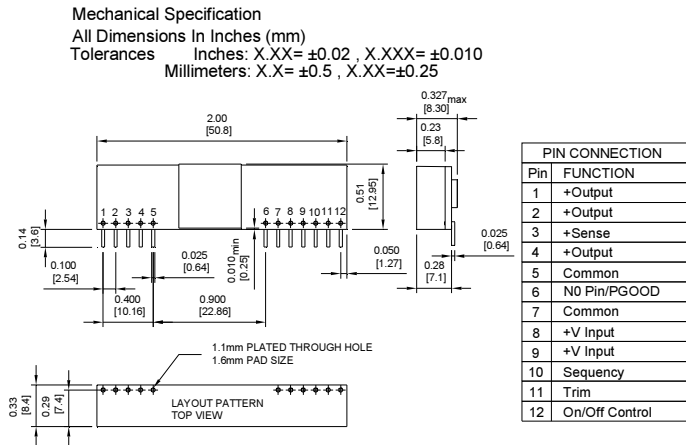

SMT Packages

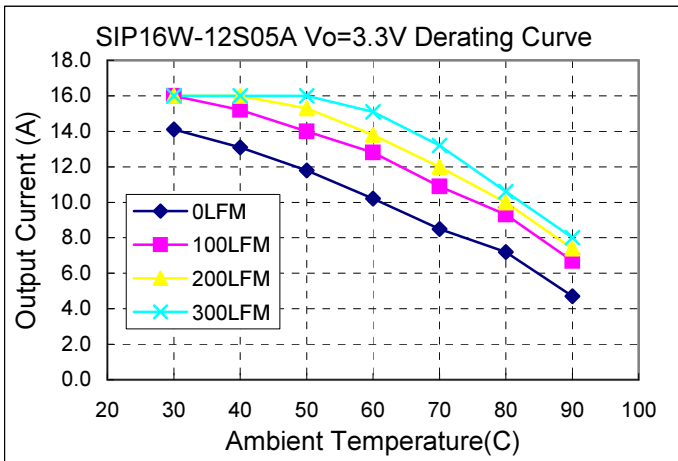
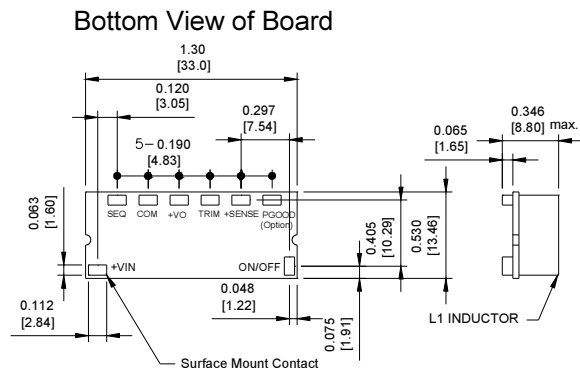

Figure2. Typical Power De-rating for 12V IN

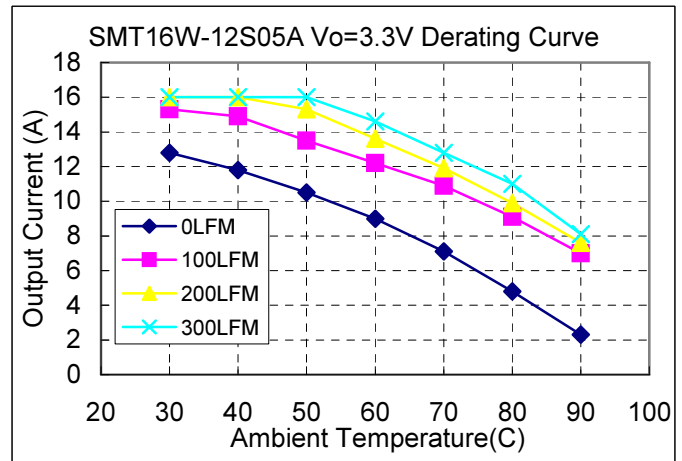

Figure3. Typical Power De-rating for 12V IN