



# DH15W10 SERIES 15 WATT 10:1 INPUT ISOLATED DC-DC CONVERTER

## Features

- Efficiency Up to 86%
- Regulated Outputs
- Fully Protected (OCP/OVP/UVLO)
- 4000Vac I/O Isolation
- Operating Temperature -40 to +80°C
- UL 1741, CSA-C22.2 No.107.1, EN62109-1 Approval
- Shock & Vibration MIL-STD-810F Compliant
- 5000m Operating Altitude
- Input Reverse Polarity Protection



MODEL NUMBER	INPUT VOLTAGE	OUTPUT VOLTAGE	OUTPUT CURRENT		INPUT CURRENT		% EFF. (1)	CAPACITOR LOAD MAX.
			MIN.	MAX.	NO LOAD	FULL LOAD		
DH15W10-800S05	150-1500 VDC	5 VDC	0 mA	2.00 A	0.5 mA	17 mA	73.5	2000uF
DH15W10-800S12	150-1500 VDC	12 VDC	0 mA	1.25 A	0.5 mA	23 mA	81.5	1250uF
DH15W10-800S15	150-1500 VDC	15 VDC	0 mA	1.00 A	0.5 mA	23 mA	83	1000uF
DH15W10-800S24	150-1500 VDC	24 VDC	0 mA	0.625 A	0.5 mA	22 mA	86	625uF

**NOTE:**

1. Nominal input voltage 800 V<sub>dc</sub>.
2. Measured at nominal input voltage.

## PART NUMBER

Series	Nominal Input Voltage	Number of Outputs	Nominal Output Voltage	Installation Type
DH15W10-	II	O	XX	Y
DH15W10	800 : 800 VDC	S : Single	05 : 05VDC 12 : 12VDC 15 : 15VDC 24 : 24VDC	P : PCB Mount ST : Screw Terminal DR : DIN Rail

**Part Number Example:**

**DH15W10-800S12P:** 15W, 10:1 150-1500Vdc Input, Single 12Vdc Output, PCB Mounting



# DH15W10 Series

## TECHNICAL SPECIFICATIONS

(All specifications are typical at nominal input, full load at 25°C unless otherwise noted.)

### ABSOLUTE MAXIMUM RATINGS

PARAMETER	NOTES and CONDITIONS	Device	Min.	Typ.	Max.	Units
Input Voltage	Continuous	All	-1500		1500	V <sub>dc</sub>
Operating Temperature	With de-rating, above 50°C	All	-40		80	°C
Storage Temperature		All	-40		85	°C

### INPUT CHARACTERISTICS

PARAMETER	NOTES and CONDITIONS	Device	Min.	Typ.	Max.	Units
Operating Input Voltage		All	150	800	1500	V <sub>dc</sub>
Input Under Voltage Lockout						
Turn-On Voltage Threshold	Full load	All	125	140	147	V <sub>dc</sub>
Turn-Off Voltage Threshold	Full load	All	112	130	137	V <sub>dc</sub>
Lockout Hysteresis Voltage	Full load	All		10		V <sub>dc</sub>
Maximum Input Current	V <sub>in</sub> =150V, Full load	5Vo Others		0.088 0.12		A
No-Load Input Current	V <sub>in</sub> =800V, I <sub>o</sub> =0A		See Model Number Table			mA
Input Filter	Capacitive	All				
Inrush Current	V <sub>in</sub> =800V <sub>dc</sub> , Cold start at 25°C	All		65	150	A

### OUTPUT CHARACTERISTICS

PARAMETER	NOTES and CONDITIONS	Device	Min.	Typ.	Max.	Units
Voltage Set Point Accuracy	V <sub>in</sub> =800V, Full load, T <sub>c</sub> =25°C	All	-2.0		+2.0	%
Output Voltage Regulation						
Load Regulation	Full load to no load	All			±1.0	%
Line Regulation	V <sub>in</sub> =High line to low line, full load	All			±1.0	%
Temperature Coefficient	T <sub>c</sub> =-40°C to 80°C	All			±0.15	%/°C
Output Voltage Ripple and Noise (5Hz to 20MHz bandwidth)						
Peak-to-Peak	Full load, 10uF aluminum capacitor and 0.1uF ceramic capacitor	5Vo 12Vo 15Vo 24Vo			100 120 150 150	mV
Output Current Range	V <sub>in</sub> = 150 to 1500V		See Model Number Table			A
Over Current Protection	Hiccup mode. Auto recovery	All	110		300	%
Short Circuit Protection		All	Continuous, Auto Recovery			
External Load Capacitance	Full load (Constant resistive load)		See Model Number Table			uF
Over Voltage Protection	IC component to clamp (auto recovery)	5Vo 12Vo 15Vo 24Vo			8 16 19 30	V <sub>dc</sub>

### EFFICIENCY

PARAMETER	NOTES and CONDITIONS	Device	Min.	Typ.	Max.	Units
100% Load	V <sub>in</sub> =800V, Full load		See Model Number Table			%

### DYNAMIC CHARACTERISTICS

PARAMETER	NOTES and CONDITIONS	Device	Min.	Typ.	Max.	Units
Output Voltage Current Transient						
Error Band	75% to 100% of I <sub>o,max</sub> . step load change di/dt=0.1A/us	All			±5	%
Recovery Time	(within 1% V <sub>out</sub> nominal)	All			250	us



# DH15W10 Series

PARAMETER	NOTES and CONDITIONS	Device	Min.	Typ.	Max.	Units
Turn-On Delay and Rise Time	Full load (Constant resistive load)					
Turn-On Delay Time, From Input	$V_{in\_min.}$ to 10% $V_{o\_set}$ , Power up	All		200		ms
Output Voltage Rise Time	10% $V_{o\_set}$ to 90% $V_{o\_set}$	All		8		ms

## ISOLATION CHARACTERISTICS

PARAMETER	NOTES and CONDITIONS	Device	Min.	Typ.	Max.	Units
Isolation Voltage (100% Factory Hi-Pot Tested @2sec.)	1 Minute; input to output	All			4000 5656	$V_{ac}$ $V_{dc}$
Isolation Resistance	Input to output	All	100			M $\Omega$
Isolation Capacitance	Input to output	All		1100		pF

## FEATURE CHARACTERISTICS

PARAMETER	NOTES and CONDITIONS	Device	Min.	Typ.	Max.	Units
Switching Frequency	Pulse width modulation (PWM) ( $V_{in} = 150V_{dc} - 1500V_{dc}$ , Full load)	All	25		75.6	KHz

## GENERAL SPECIFICATIONS

PARAMETER	NOTES and CONDITIONS	Device	Min.	Typ.	Max.	Units
MTBF	$I_o = 100\%$ of $I_{o\_max.}$ ; MIL-HDBK - 217F_Notice 1, GB, 25°C	All	300			K hours
Weight	Pin out package (DH15W10-800SXXP) Lock screw wiring (DH15W10-800SXXST) Lock screw wiring+track (DH15W10-800SXXDR)	All		170 210 215		grams
Case Material	Plastic, PBT, UL 94V-0					
Base Plate Material	Non-Conductive Base					
Potting Material	UL 94V-0					
Pin Material	Base: Copper Plating: Nickel with Matte Tin					
Shock/Vibration	MIL-STD-810F					
Humidity	95% RH max. Non condensing					
Altitude	5000m Operating altitude, 12000m Transport altitude					
Thermal Shock	MIL-STD-810F					

## EMC SPECIFICATIONS (External components required, please refer to application note.)

EMI	Meets EN 55032 Compliant (with external filter)					Class A
ESD	EN 61000-4-2	Level 3: Air $\pm 8kV$ , Contact $\pm 4kV$				Perf. Criteria A
Radiated Immunity	EN 61000-4-3	Level 3: 80~1000MHz, 10V/m				Perf. Criteria A
Fast Transient	EN 61000-4-4	Level 3: On power input port, $\pm 2kV$ , external input capacitor required				Perf. Criteria A
Surge	EN 61000-4-5	Level 4: Line to line, $\pm 2kV$ (with external components)				Perf. Criteria A
Conducted Immunity	EN 61000-4-6	Level 3: 0.15~80MHz, 10V				Perf. Criteria A
Power Frequency Magnetic Field Immunity	EN 61000-4-8	50/60Hz, 3A/m (r.m.s.)				Perf. Criteria A
Application Note Link						<a href="#">DH15W10 Series App Notes</a>



## CHARACTERISTIC CURVE

### Power Derating Curve

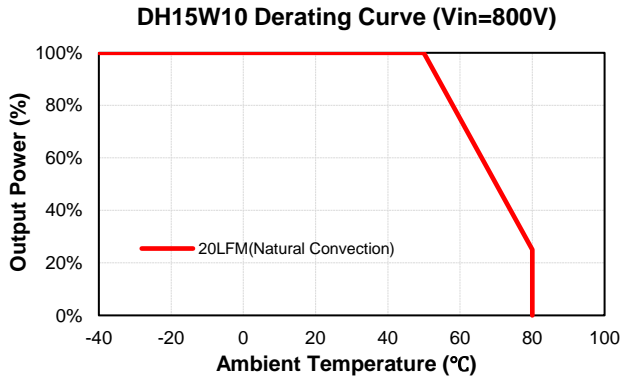

### Performance Data

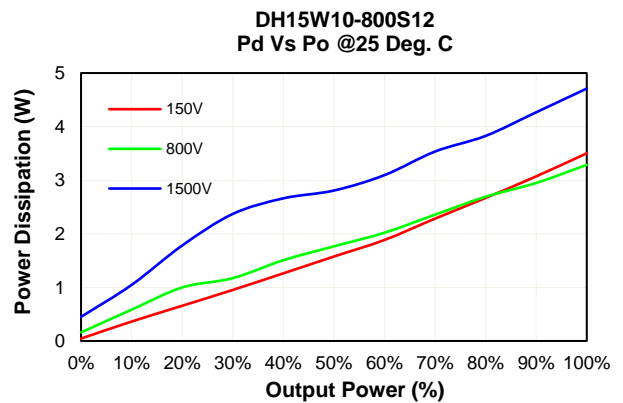
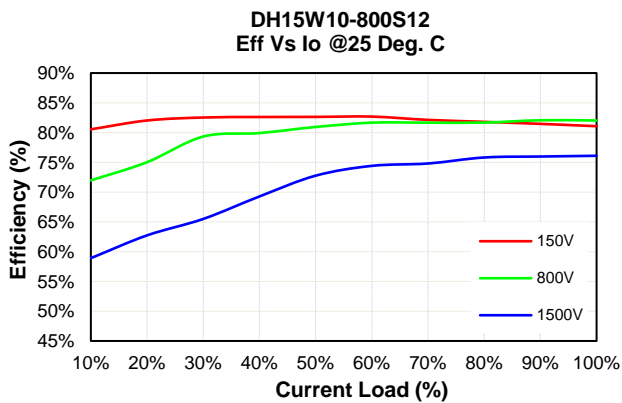
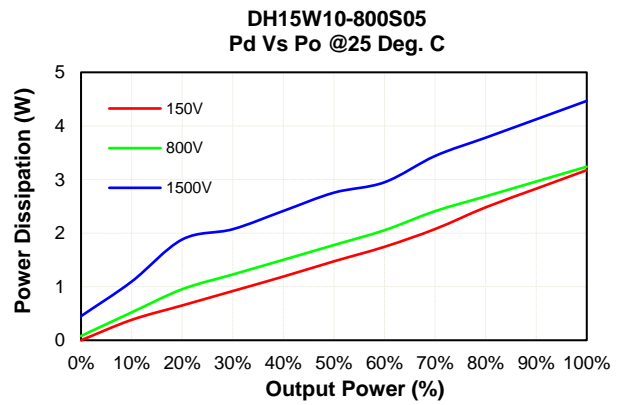
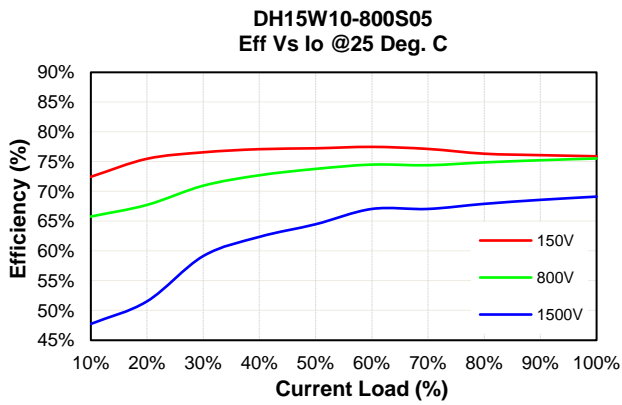



# DH15W10 Series

**DH15W10-800S15**  
Eff Vs Io @25 Deg. C

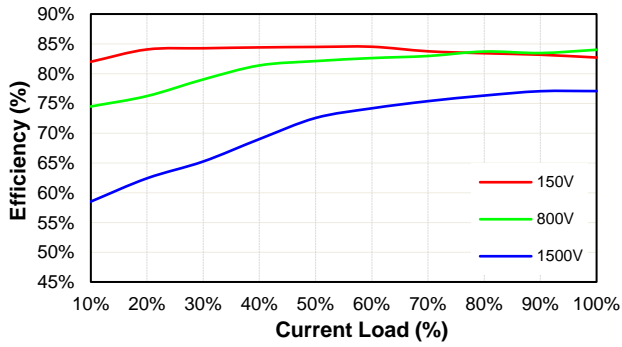

**DH15W10-800S15**  
Pd Vs Po @25 Deg. C

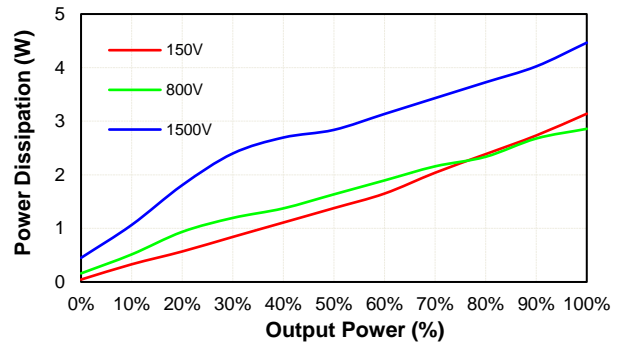

**DH15W10-800S24**  
Eff Vs Io @25 Deg. C

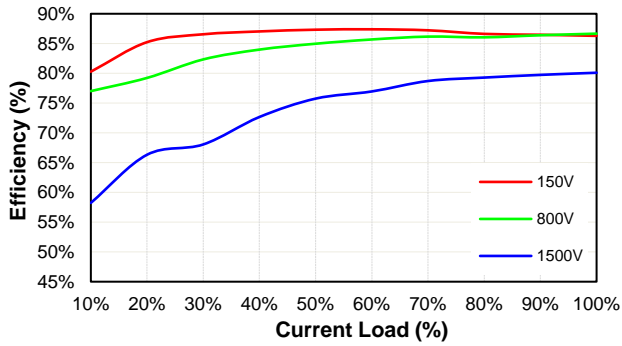

**DH15W10-800S24**  
Pd Vs Po @25 Deg. C

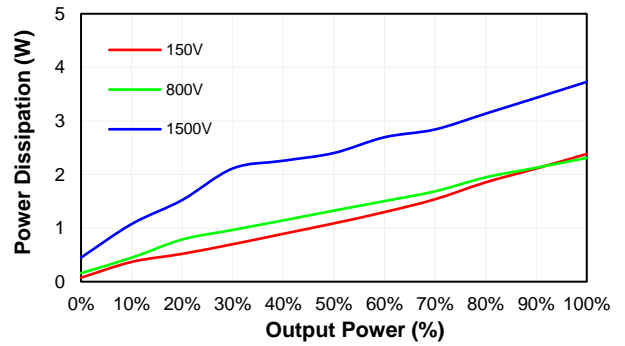



# DH15W10 Series

## MECHANICAL SPECIFICATION

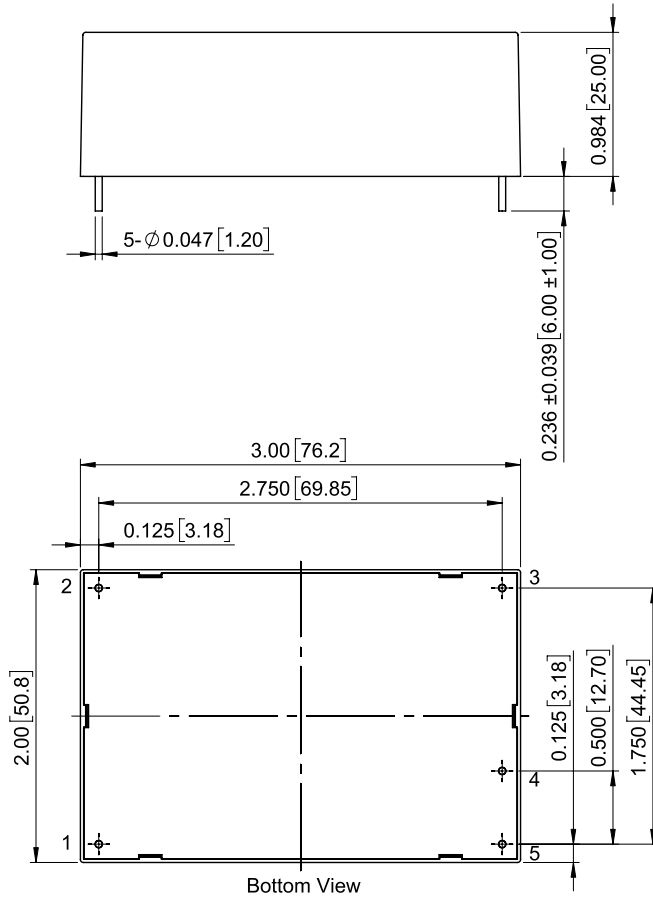

### DH15W10-800SXXP

All Dimensions in Inches[mm]

Tolerance Inches: x.xx=±0.03, x.xxx=±0.020

Millimeters: x.x=±0.7, x.xx=±0.50

#### Pin Connection

Pin	Function
1	-Vin
2	+Vin
3	NC
4	-Vout
5	+Vout

Note: Pin Size is  $\varnothing 0.047 \pm 0.004$  Inch [ $\varnothing 1.20 \pm 0.1$  mm]

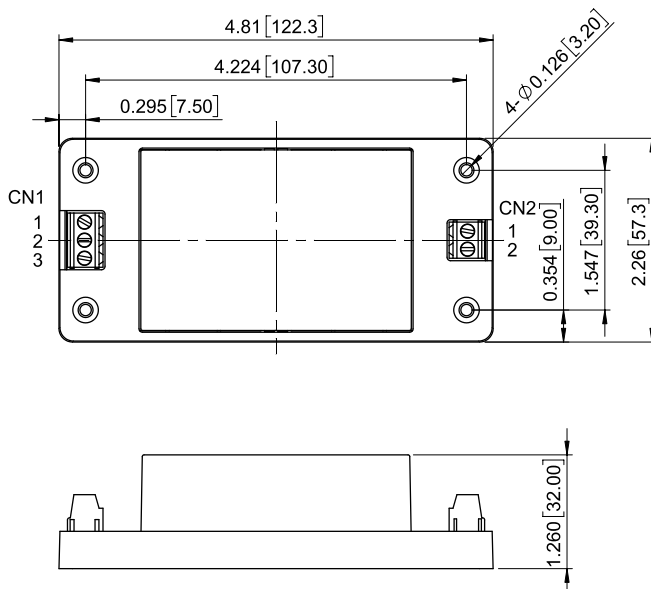

### DH15W10-800SXXST

All Dimensions in Inches[mm]

Tolerance Inches: x.xx=±0.03, x.xxx=±0.020

Millimeters: x.x=±0.7, x.xx=±0.50

AC Input Connector(CN1): DINKLE EK508V-03P or equivalent

Pin	Function	Mating Wire Range
1	-Vin	12~24 AWG
2	NC	
3	+Vin	

DC Input Connector(CN2): DINKLE EK508V-02P or equivalent

Pin	Function	Mating Wire Range
1	+Vout	12~24 AWG
2	-Vout	

Note: Recommended torque setting for terminal is 5kgf-cm



# DH15W10 Series

## MECHANICAL SPECIFICATION

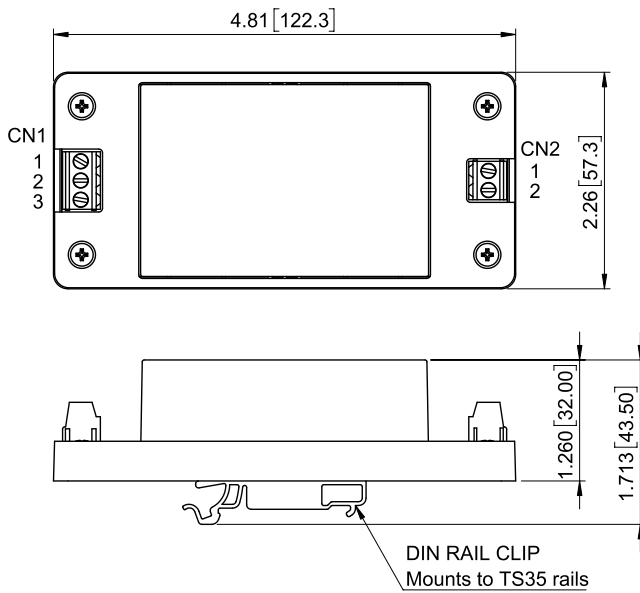

### DH15W10-800SXXDR

All Dimensions in Inches[mm]

Tolerance Inches: x.xx=±0.03, x.xxx=±0.020

Millimeters: x.x=±0.7, x.xx=±0.50

AC Input Connector(CN1):DINKLE EK508V-03P or equivalent

Pin	Function	Mating Wire Range
1	-Vin	12~24 AWG
2	NC	
3	+Vin	

DC Input Connector(CN2):DINKLE EK508V-02P or equivalent

Pin	Function	Mating Wire Range
1	+Vout	12~24 AWG
2	-Vout	

Note:Recommended torque setting for terminal is 5kgf-cm