

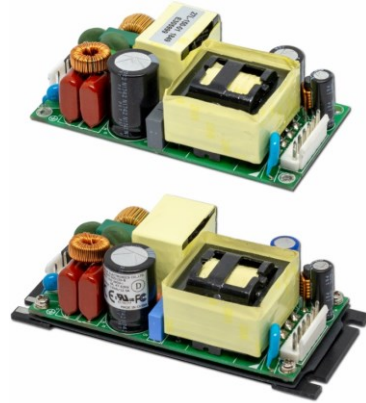

CFM150S SERIES 150 WATT OPEN FRAME AC-DC MODULES

Features

- Universal Input Range 90~264Vac
- High Efficiency up to 94%
- 2"x 4" Open Frame Compact Size
- Class I & Class II (NOTE7)
- 120W with Natural Convection (CFM150SXXX)
- 150W with Natural Convection (CFM150SXXXB)
- Peak Power Operation up to 180Watt for 5s
- No Load Input Power Consumption<150mW
- Approval Safety IEC/EN/UL 62368-1 Ed 3.0
- Operating Altitude 5000m
- Continuous Short Circuit Protection
- Over Voltage Protection
- Active PFC Function



MODEL NUMBER	OUTPUT VOLTAGE	OUTPUT CURRENT		VOLTAGE ACCURACY NOTE1	RIPPLE & NOISE NOTE2	VLOTAGE ADJ. RANGE	LINE REGULATION NOTE3	LOAD REGULATION NOTE4	% EFF. (Typ.) NOTE5
		NATURAL CONVECTION	BASE COOLING						
CFM150S120	12 V	10.0 A	12.5 A	1%	120 mV	±8%	±0.5%	±1%	93%
CFM150S240	24 V	5.0 A	6.25 A	1%	240 mV	±8%	±0.5%	±1%	94%
CFM150S280	28 V	4.28 A	5.35 A	1%	280 mV	±8%	±0.5%	±1%	94%
CFM150S360	36 V	3.33 A	4.16 A	1%	360 mV	±8%	±0.5%	±1%	94%
CFM150S480	48 V	2.5 A	3.125 A	1%	480 mV	±8%	±0.5%	±1%	94%

Note:

1. Voltage accuracy is set at 100% full load.
2. Add a 0.1uF ceramic capacitor and a 10uF E.L. capacitor to output for ripple & noise measuring @20MHz BW.
3. Line regulation is measured from 0V_{ac} to 264V_{ac} with 100% full load.
4. Load regulation measured from 0% to 100% full load.
5. Typical efficiency at 230 Vac and 75% full load at 25°C.
6. Standard input and output connectors (CN1 and CN2) wafer with TAIWAN KING PIN TERMINAL PVHI series and mate with JST housing VHR series or equivalent.
7. Conductive: Class I & Class II meets Class B Radiation: Class I meet Class B, Class II meet Class A.

PART NUMBER

Series	Number of Outputs	Nominal Output Voltage	Type
CFM150	X	XXX	-X (Option)
CFM150	S : Single	120 : 12V 240 : 24V 280 : 28V 360 : 36V 480 : 48V	Blank : Open Frame B : Base Cooling

Part Number Example:

CFM150S120B: With Base, 150W, Single 12V_{dc} Output



CFM150S Series

TECHNICAL SPECIFICATIONS

(All specifications are typical at nominal input, full load at 25°C unless otherwise noted.)

ABSOLUTE MAXIMUM RATINGS

PARAMETER	NOTES and CONDITIONS	Device	Min.	Typ.	Max.	Units
Input Voltage		All	90		264	V _{ac}
Operating Temperature	100V _{ac} ~264V _{ac} See Derating Curve (V _{in} =90V _{ac} , Operate @-30°C~80°C)	All	-40		80	°C
Storage Temperature		All	-40		85	°C
Operating Altitude		All			5000	m

INPUT CHARACTERISTICS

PARAMETER	NOTES and CONDITIONS	Device	Min.	Typ.	Max.	Units
Operating Voltage Range		All	90		264	V _{ac}
Input Frequency Range		All	47		63	Hz
Maximum Input Current	100% Load, V _{in} =100V _{ac}	All			2	A
Power Factor	100% Load, V _{in} =230V _{ac}	All	0.9			
Inrush Current	V _{in} =240V _{ac} , Cold start @25°C	All			100	A
Leakage Current (Touch)		All			0.1	mA
Leakage Current (Earth)		All			1	mA
Under Voltage Protection		All	60		75	V _{ac}

OUTPUT CHARACTERISTICS

PARAMETER	NOTES and CONDITIONS	Device	Min.	Typ.	Max.	Units
Output Voltage Set Point	V _{in} =90V _{ac} ~264V _{ac} , I _o =I _o max., ambient temperature=25°C	CFM150S120/-B	11.88	12	12.12	V _{dc}
		CFM150S240/-B	23.76	24	24.24	
		CFM150S280/-B	27.72	28	28.28	
		CFM150S360/-B	35.64	36	36.36	
		CFM150S480/-B	47.52	48	48.48	
Output Voltage Adjustment	CFM150S ≤ Rated output power 120W CFM150S-B ≤ Rated output power 150W	CFM150S120/-B	11.04		12.96	V _{dc}
		CFM150S240/-B	22.08		25.92	
		CFM150S280/-B	25.76		30.24	
		CFM150S360/-B	33.12		38.88	
		CFM150S480/-B	44.16		51.84	
Operating Output Current Range	CFM150SXXX V _{in} = 90V _{ac} ~200V _{ac} see typical current V _{in} = 200V _{ac} ~264V _{ac} see max. current	CFM150S120	0	10	11.67	A
		CFM150S240	0	5	5.83	
		CFM150S280	0	4.28	4.99	
		CFM150S360	0	3.33	3.88	
		CFM150S480	0	2.5	2.92	
	V _{in} =90V _{ac} ~264V _{ac} , See Derating Curve	CFM150S120-B	0		12.5	A
		CFM150S240-B	0		6.25	
		CFM150S280-B	0		5.35	
		CFM150S360-B	0		4.16	
		CFM150S480-B	0		3.125	
Holdup Time	V _{in} =115V _{ac}	All	20	25		ms
Output Voltage Regulation						
Load Regulation	10% Load to full load	All			±1.0	%
Line Regulation	V _{in} =High line to low line	All			±0.5	%



CFM150S Series

PARAMETER	NOTES and CONDITIONS	Device	Min.	Typ.	Max.	Units
Over Voltage Protection	Latch off (AC recycle to reset)	CFM150S120/-B CFM150S240/-B CFM150S280/-B CFM150S360/-B CFM150S480/-B			14.2 29.2 34.2 44.2 58.2	V _{dc}
Output Ripple and Noise	1. Add a 0.1uF ceramic capacitor and a 10uF aluminum electrolytic capacitor to output. 2. Oscilloscope is 20MHz band width. 3. Ambient temperature=25°C	CFM150S120/-B CFM150S240/-B CFM150S280/-B CFM150S360/-B CFM150S480/-B			120 240 280 360 480	mVp-p
Over Current Protection	Auto recovery	CFM150S CFM150S-B	150 120	160 130	170 140	%
Peak Power	1. V _{in} = 115V _{ac} and 230V _{ac} 2. Ambient temperature=25°C 3. Peak power should be less than 5seconds, with a maximum 10% duty cycle, peak power function by 120% load 5S and 75% load 45S	All		120		%
Short Circuit Protection	Auto recovery	All				
Load Capacitance	1. Input voltage is 115V _{ac} and 230V _{ac} 2. Output is 100% full load 3. Ambient temperature=25°C	CFM150S120/-B CFM150S240/-B CFM150S280/-B CFM150S360/-B CFM150S480/-B			12500 6200 5340 4100 3080	uF
Efficiency	1. Input voltage is 230V _{ac} . 2. Output is 75% full load 3. Ambient temperature=25°C	CFM150S120/-B CFM150S240/-B CFM150S280/-B CFM150S360/-B CFM150S480/-B		93% 94% 94% 94% 94%		%

ISOLATION CHARACTERISTICS

PARAMETER	NOTES and CONDITIONS	Device	Min.	Typ.	Max.	Units
Input to Output	1 Minute (without dielectric breakdown)	All			4000	V _{ac}
Input to Earth (Ground)	1 Minute (without dielectric breakdown)	All			2500	V _{ac}
Output to Earth (Ground)	1 Minute (without dielectric breakdown)	All			360	V _{ac}
Isolation Resistance	Input to output	All	100			MΩ

FEATURE CHARACTERISTICS

PARAMETER	NOTES and CONDITIONS	Device	Min.	Typ.	Max.	Units
Switching Frequency		All		115		kHz

GENERAL CHARACTERISTICS

PARAMETER	NOTES and CONDITIONS	Device	Min.	Typ.	Max.	Units
MTBF	I _o =100%; T _a =25°C per MIL-HDBK-217F I _o =100%; T _a =25°C per Telcordia SR332	All	471 3,343			k hours
Life Time	@75% Load, 40°C	All	26			k hours
Humidity	Non-condensing	All			93	% RH
Shock	Meets MIL-STD-810F Table 516.5, TABLE 516.5- I 10ms, each axis 3 times(±X、±Y、±Z axis)	All		75		g
Vibration	Meets MIL-STD-810F Table 514.5C-VIII, 15~2000Hz, X、Y、Z axis, 1 hr(each axis),. total 3 hrs	All		4		g



CFM150S Series

GENERAL CHARACTERISTICS

PARAMETER	NOTES and CONDITIONS	Device	Min.	Typ.	Max.	Units
Weight	Open frame B (Base Cooling)	All		200 240		grams
Dimension	Open Frame B (Base Cooling)	All	4.000x2.000x1.283 Inches (101.6x50.80x32.6 mm) 4.598x2.000x1.362 Inches (116.8x50.80x34.6 mm)			
Safety	Class I & Class II, IEC/EN/UL 62368-1					Ed 3.0
EMC Emission	EN 55032:2015+A11:2020 Class B, 47 CFR FCC Part 15 Subpart B, EN 61204-3:2018, EN 61000-3-2:2019, EN 61000-3-3:2013+A1:2019, EN 61000-6-3:2007+A1:2011+AC:2012, EN 61000-6-4:2019					
Conducted Disturbance	EN 55032:2015+A11:2020, 47 CFR FCC Part 15 (Class I & Class II meets Class B)					Class B
Radiated Disturbance	EN 55032:2015+A11:2020, 47 CFR FCC Part 15 (Class I Meet Class B; Class II Meet Class A)					Class B
Harmonic Current Emissions	EN 61000-3-2:2019					Class A
Voltage Fluctuations & Flicker	EN 61000-3-3:2013+A1:2019					Criterion A
EMC Immunity	EN 55035:2017+A11:2020, EN 61000-6-1:2019, EN 61000-6-2:2019, EN 61204-3:2018					Criterion A
Electrostatic Discharge (ESD)	IEC 61000-4-2:2008 Air Discharge: ±8kV, Contact Discharge: ±4kV					Criterion A
Radio-Frequency, Continuous Radiated Disturbance	IEC 61000-4-3:2020					Criterion A
Electrical Fast Transient (EFT)	IEC 61000-4-4:2012, ±2kV					Criterion A
Surge	IEC 61000-4-5:2014+A1:2017, L-N: ±1kV, L-E(Ground): ±2kV					Criterion A
Conducted Disturbances, Induced by RF Fields	IEC 61000-4-6:2013+COR1:2015					Criterion A
Power Frequency Magnetic Field	IEC 61000-4-8:2009					Criterion A
Voltage Dips	IEC 61000-4-11:2020 Dip: 30% 10ms, Dip: 60% 100ms, Dip >95% 5000ms					Criterion A
Voltage Interruptions	IEC 61000-4-11:2020, >95% 5000ms					Criterion B
Application Note Link						CFM150S Series App Notes

CHARACTERISTIC CURVE

Power Derating Curve

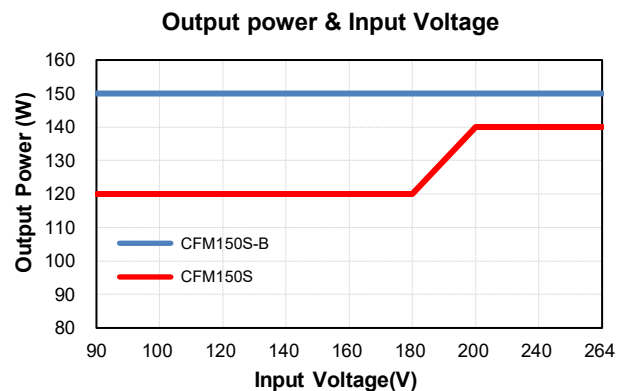
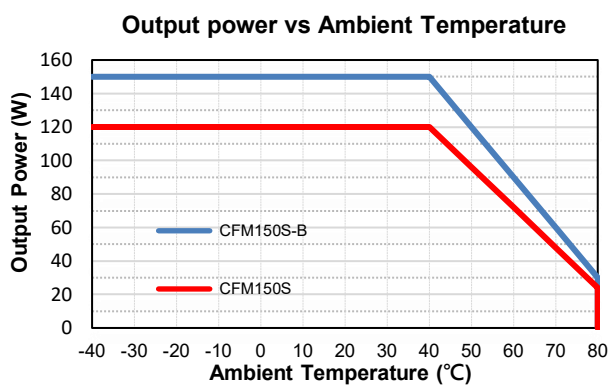



CFM150S Series

Performance Data

CFM150S120 (Eff Vs Io)

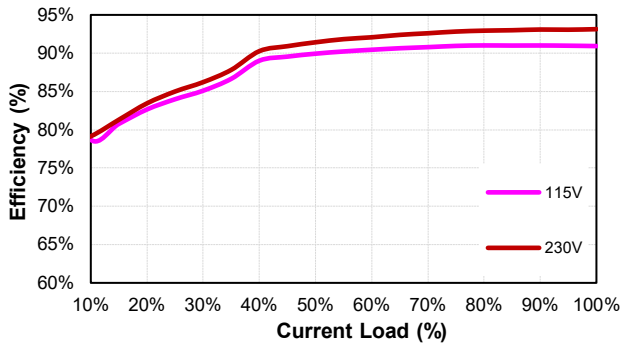

CFM150S240 (Eff Vs Io)

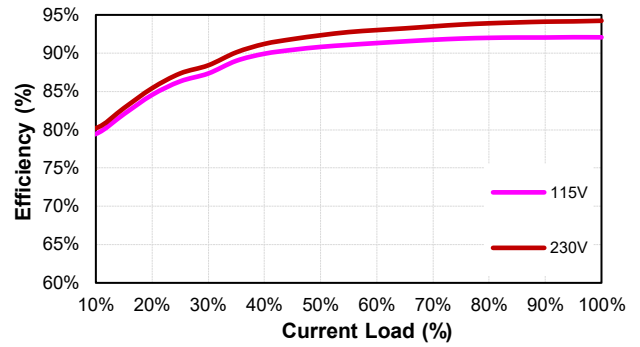

CFM150S280 (Eff Vs Io)

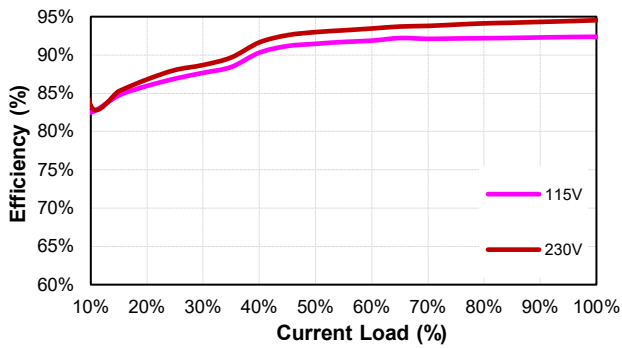

CFM150S360 (Eff Vs Io)

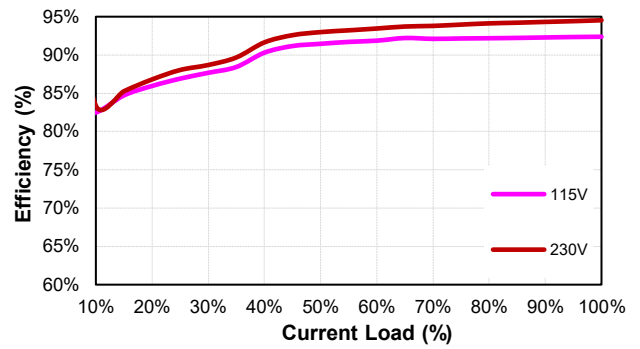

CFM150S480 (Eff Vs Io)

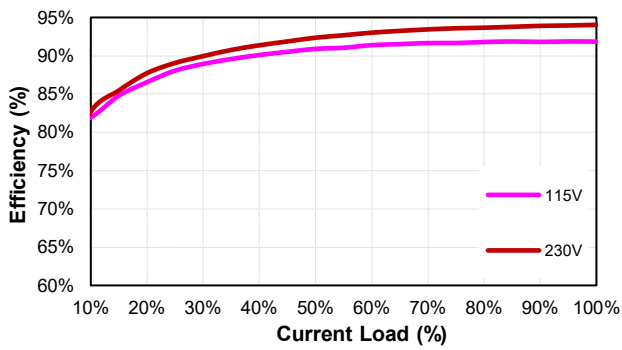



CFM150S Series

MECHANICAL SPECIFICATION

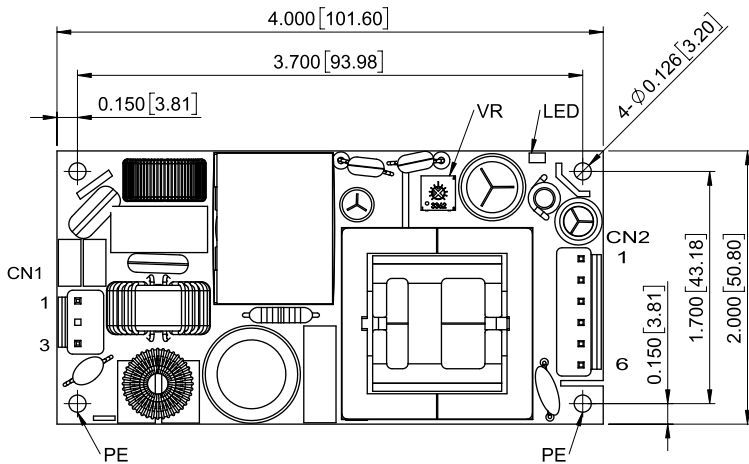

CFM150SXXX

All Dimensions in Inches[mm]

Tolerance Inches: x.xxx=±0.020

Millimeters: x.xx=±0.50

AC Input Connector(CN1):TKP PVHI-03N2 or equivalent

Pin	Function	Mating Housing	Terminal
1	ACL	JST VHR-3N or equivalent	JST SVH-21T-P1.1 or equivalent
2	-		
3	ACN		

DC Output Connector(CN2):TKP PVHI-06 or equivalent

Pin	Function	Mating Housing	Terminal
1	+Vout	JST VHR-6N or equivalent	JST SVH-21T-P1.1 or equivalent
2	+Vout		
3	+Vout		
4	-Vout		
5	-Vout		
6	-Vout		

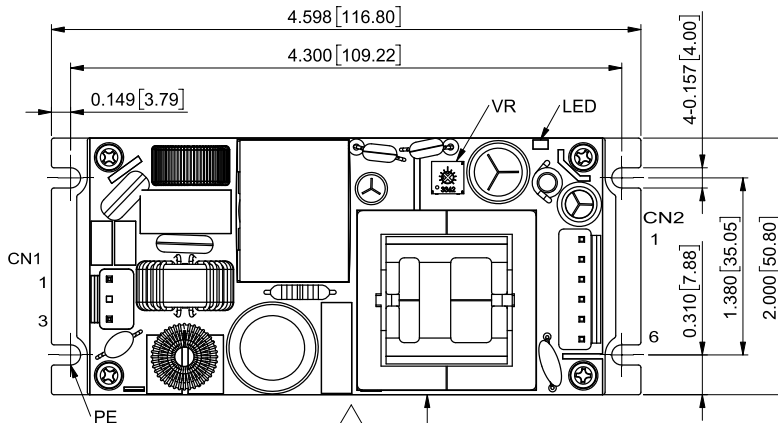
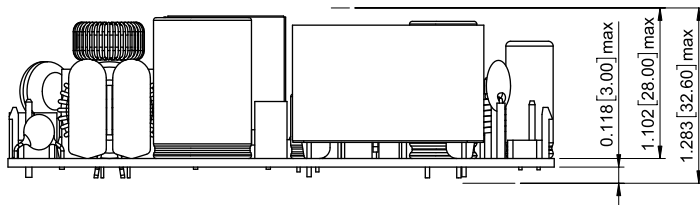

CFM150SXXX-B

All Dimensions in Inches[mm]

Tolerance Inches: x.xxx=±0.020

Millimeters: x.xx=±0.50

AC Input Connector(CN1):TKP PVHI-03N2 or equivalent

Pin	Function	Mating Housing	Terminal
1	ACL	JST VHR-3N or equivalent	JST SVH-21T-P1.1 or equivalent
2	-		
3	ACN		

DC Output Connector(CN2):TKP PVHI-06 or equivalent

Pin	Function	Mating Housing	Terminal
1	+Vout	JST VHR-6N or equivalent	JST SVH-21T-P1.1 or equivalent
2	+Vout		
3	+Vout		
4	-Vout		
5	-Vout		
6	-Vout		

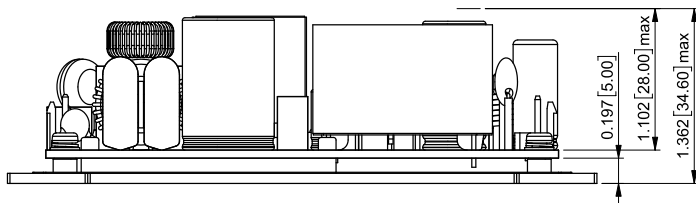
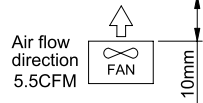

CINCON Electronics Co. Ltd.
 Add: 14F, No. 306, Sec.4, Hsin Yi Rd., Taipei, Taiwan
 Tel: 886-2-27086210
 Fax: 886-2-27029852
 E-mail: sales@cincon.com.tw
 Web: www.cincon.com