



# DH30W10 Series Application Note V10

## ISOLATED DC-DC CONVERTER DH30W10 Series APPLICATION NOTE



Approved By:

Department	Approved By	Checked By	Written By
Research and Development Department	Ovid	Yang/Zhu Hai	Zheng
Design Quality Department	Benny	JoJo	



# DH30W10 Series Application Note V10

---

## Contents

1. Introduction .....	3
2. Pin Function Description .....	3
3. Connection for Standard Use .....	4
4. Test Set-Up .....	4
5. Recommend Layout, PCB Footprint and Soldering Information .....	4
6. Features and Functions .....	5
6.1 UVLO ( <i>Under Voltage Lock Out</i> ) .....	5
6.2 <i>Over Current/Short Circuit Protection</i> .....	5
6.3 <i>Over Voltage Protection</i> .....	5
6.4 <i>Input Reverse Polarity Protection</i> .....	5
7. Output Considerations .....	5
7.1 <i>Output Ripple and Noise</i> .....	5
7.2 <i>Output Capacitance</i> .....	6
8. Main Features and Functions .....	7
8.1 <i>Operating Temperature Range</i> .....	7
8.2 <i>Convection Requirements for Cooling</i> .....	7
8.3 <i>Thermal considerations</i> .....	7
8.4 <i>Power Derating</i> .....	7
9. <i>Installation Instruction</i> .....	7
10. Safety & EMC .....	8
10.1 <i>Input Fusing and Safety Considerations</i> .....	8
10.2 <i>EMC Considerations</i> .....	8



# DH30W10 Series Application Note V10

## 1. Introduction

The DH30W10 series of DC-DC converters offers 30 watts of output power with single output voltages of 12, 15, 24, 48VDC. It has ultrawide (10:1) input voltage range of 150 to 1500VDC (800VDC nominal) and 4000VAC reinforced isolation.

Fully protected against input UVLO (under voltage lock out), output over-current, output over-voltage and continuous short circuit conditions.

DH30W10 series can be widely used in photovoltaic power generation and high-voltage frequency conversion and other occasions to provide stable working voltage for load equipment.

## 2. Pin Function Description

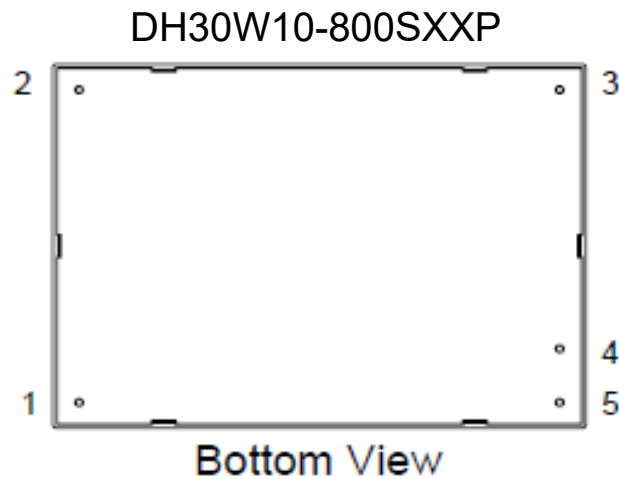

No	Label	Function	Description	Reference
1	-Vin	-V Input	Negative Supply Input	<b>Section 10.1</b>
2	+Vin	+V Input	Positive Supply Input	<b>Section 10.1</b>
3	NC	NC	No Connection with Pin	
4	-Vout	-V Output	Negative Power Output	<b>Section 7.1/7.2</b>
5	+Vout	+V Output	Positive Power Output	<b>Section 7.1/7.2</b>



# DH30W10 Series Application Note V10

## 3. Connection for Standard Use

The connection for standard use is shown below. External output capacitors (C1, C2) are recommended to reduce output ripple and noise, 10uF electrolytic capacitor and 0.1uF ceramic capacitor for all models.

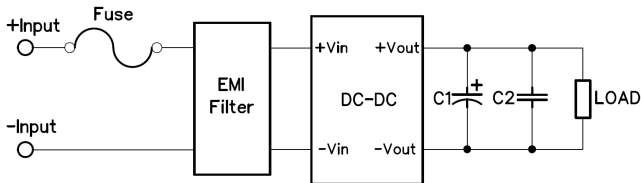

Symbol	Component	specification
FUSE	Input fuse	4A/1500Vdc
EMI Filter	External EMI filter	<b>See 9.2 EMC Considerations</b>
C1	External capacitor on the output side	10 uF/50V electrolytic capacitor
C2	External capacitor on the output side	0.1uF/50V ceramic capacitor

## 4. Test Set-Up

The basic test set-up to measure parameters such as efficiency and load regulation is shown below. When testing the Cincon's DH30W10 series under any transient conditions, please ensure that the transient response of the source is sufficient to power the equipment under test. We can calculate:

- Efficiency
- Load regulation and line regulation

The value of efficiency is defined as:

$$\eta = \frac{V_o \times I_o}{V_{in} \times I_{in}} \times 100\%$$

Where:

- $V_o$  is output voltage
- $I_o$  is output current
- $V_{in}$  is input voltage
- $I_{in}$  is input current

The value of load regulation is defined as:

$$Load\ reg. = \frac{V_{FL} - V_{NL}}{V_{NL}} \times 100\%$$

Where:

- $V_{FL}$  is the output voltage at full load
- $V_{NL}$  is the output voltage at 10% load

The value of line regulation is defined as:

$$Line\ reg. = \frac{V_{HL} - V_{LL}}{V_{LL}} \times 100\%$$

Where:

$V_{HL}$  is the output voltage of maximum input voltage at full load

$V_{LL}$  is the output voltage of minimum input voltage at full load

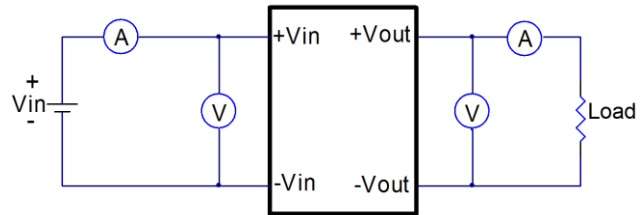

DH30W10 Series Test Setup

## 5. Recommend Layout, PCB Footprint and Soldering Information

The system designer or end user must ensure that metal and other components in the vicinity of the converter meet the spacing requirements for which the system is approved. Low resistance and inductance PCB layout traces are the norm and should be used where possible. Due consideration must also be given to proper low impedance tracks between power module, input and output grounds. The recommended footprints and soldering profiles are shown below.

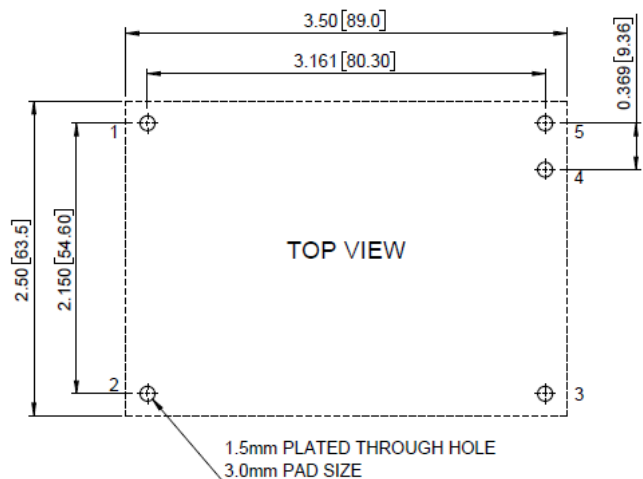

Note: Dimensions are in inches (millimeters)



# DH30W10 Series Application Note V10

Clean the soldered side of the module with a brush, prevent liquid from getting into the module. Do not clean by soaking the module into liquid. Do not allow solvent to come in contact with product labels or resin case as this may change the color of the resin case or cause deletion of the letters printed on the product label. After cleaning, dry the modules well.

The suggested soldering iron is  $420 \pm 10^\circ\text{C}$  for up to 4-10 seconds (less than 90W) used in double PCB and multilayer PCB, The other one is used in the single PCB is  $385 \pm 10^\circ\text{C}$  for up to 2-6 seconds (less than 90W). Furthermore the recommended soldering profile is shown below.

Lead Free Wave Soldering Profile

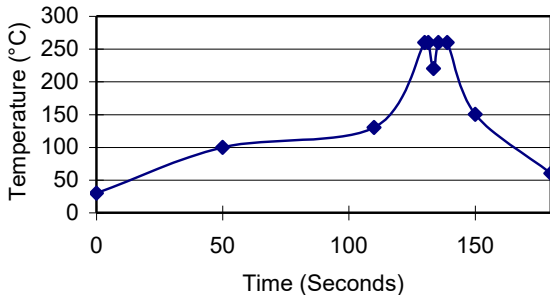

## 6. Features and Functions

### 6.1 UVLO (Under Voltage Lock Out)

Input under voltage lockout is standard on the DH30W10 series unit. The unit will shut down when the input voltage drops below a lower threshold, and the unit will operate when the input voltage goes above the upper threshold.

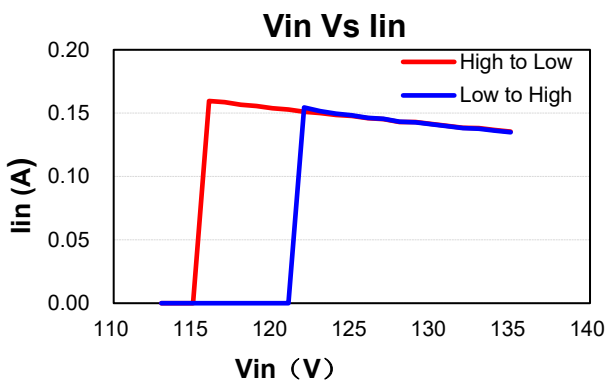

### 6.2 Over Current/Short Circuit Protection

All models have internal over current and continuous short circuit protection. The unit operates normally once the fault condition is removed. At the point of current limit inception, the converter will go into hiccup mode protection.

### 6.3 Over Voltage Protection

All different voltage models have a fully continuous over voltage protection. The power module will supply OVP. In the event of happen the OVP, the converter will shut down, the converter will go into hiccup mode protection.

### 6.4 Input Reverse Polarity Protection

All models have input reverse polarity protection to prevent damage to power module when the input polarity is reversed.

## 7. Output Considerations

### 7.1 Output Ripple and Noise

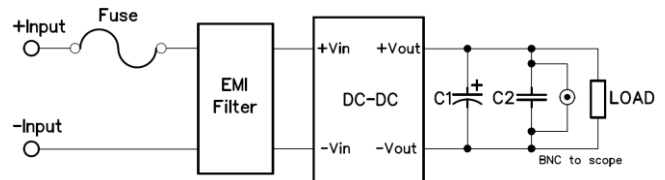

Output ripple and noise measured with 10uF electrolytic capacitor and 0.1uF ceramic capacitor across output, a 20 MHz bandwidth oscilloscope is normally used for the measurement.

The conventional ground clip on an oscilloscope probe should never be used in this kind of measurement. This clip, when placed in a field of radiated high frequency energy, acts as an antenna or inductive pickup loop, creating an extraneous voltage that is not part of the output noise of the converter.

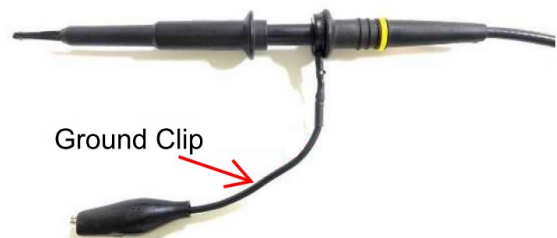



## DH30W10 Series Application Note V10

The test set-up for noise and ripple measurements is shown in below Measured method: Add a C2=0.1uF ceramic capacitor and a C1=10uF electrolytic capacitor to output at 20 MHz Band Width.

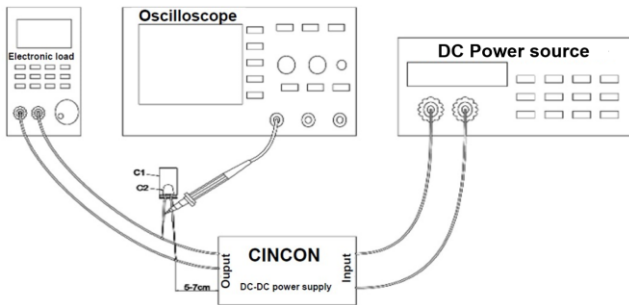

### 7.2 Output Capacitance

The DH30W10 series converters need external capacitors. For good transient response, low ESR output capacitors should be located closed to the point of load (<20mm). PCB design emphasizes low resistance and inductance tracks in consideration of high current applications. Output capacitors with their associated ESR values have an impact on loop stability and bandwidth.



# DH30W10 Series Application Note V10

## 8. Main Features and Functions

### 8.1 Operating Temperature Range

The DH30W10 series converters can be operated within a wide ambient temperature range of  $-40^{\circ}\text{C}$  to  $80^{\circ}\text{C}$ . Consideration must be given to the derating curves when ascertaining maximum power that can be drawn from the converter. The maximum power drawn from models is influenced by usual factors, such as:

- Input voltage range
- Output load current
- Forced air or natural convection

### 8.2 Convection Requirements for Cooling

To predict the approximate cooling needed for the 3.5"×2.5" module, refer to the power derating curves in **datasheet**. These derating curves are approximations of the ambient temperatures and airflows required to keep the power module temperature below its maximum rating.

### 8.3 Thermal considerations

The power module operates in a variety of thermal environments; however, sufficient cooling should be provided to help ensure reliable operation of the unit. Heat is removed by conduction, convection, and radiation to the surrounding environment. The example is presented in **datasheet**. The power output of the module should not be allowed to exceed rated power ( $V_{o\_set} \times I_{o\_max}$ ).

### 8.4 Power Derating

The operating ambient temperature range of DH30W10 series is  $-40^{\circ}\text{C}$  to  $+80^{\circ}\text{C}$ . When operating the DH30W10 series, proper derating or cooling is needed (refer to **datasheet**).

## 9. Installation Instruction

The DH30W10-800SXXP mounting holes are 1.6mm. Please allow 4mm side clearance from the components and all side of the PCB and CASE. Allow 5mm clearance above the highest parts on the PCB and CASE.

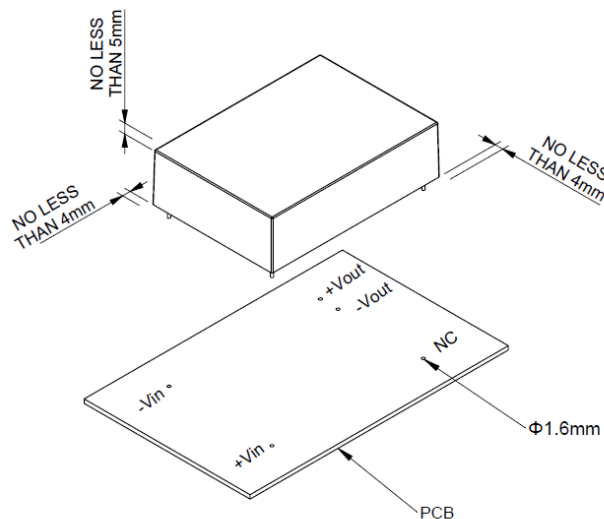



# DH30W10 Series Application Note V10

## 10. Safety & EMC

### 10.1 Input Fusing and Safety Considerations

The DH30W10 series converters have no internal fuse. In order to achieve maximum safety and system protection, always use an input line fuse. We recommended a 4A/1500V<sub>dc</sub> fuse for all modules (as shown).

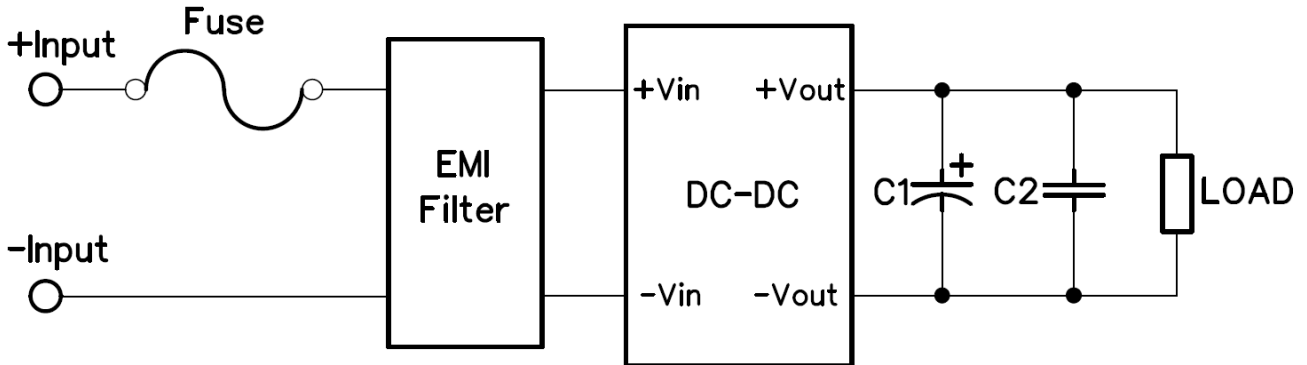

### 10.2 EMC Considerations

EMI Test standard: EN 55032 Conducted & Radiated Emission

To use DH30W10 series, connection shown below and external components are required to meet EN 55032 Class A

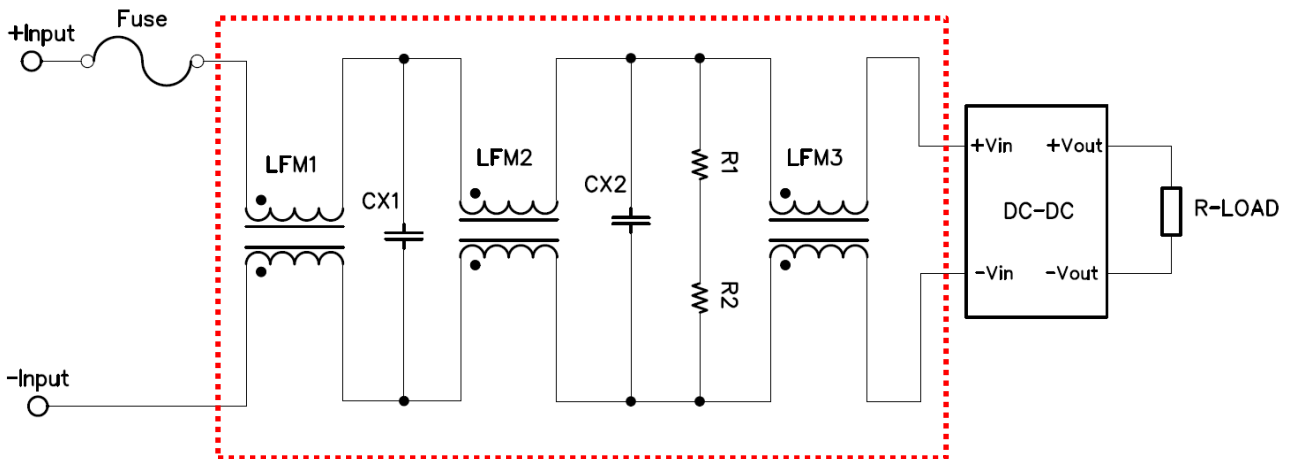





## DH30W10 Series Application Note V10

Model Number	Conduction & Radiation Class A			
	Fuse	LFM1, LFM2, LFM3	CX1, CX2	R1, R2
DH30W10-800SXXP	4A/1500V <sub>dc</sub>	20mH SQ1515	0.33uF/1500V <sub>dc</sub>	1/2W 3M/≥800V

**Note:**

Fuse:

Fuse 4A/1500V<sub>dc</sub>

LFM1, LFM2, LFM3:

CMCK DIP SQ1515 0.1mm/66T 20mH MIN SEND POWER

CX1, CX2:

0.33uF/1500V<sub>dc</sub> X2 cap. (CHIEFCON)

R1, R2:

1/2W 3M 2000V (PDC FVS series high voltage thick film resistor)

### CINCON ELECTRONICS CO., LTD.

**Headquarters:**

14F, No.306, Sec.4, Hsin Yi Rd.  
Taipei, Taiwan  
Tel: 886-2-27086210  
Fax: 886-2-27029852  
E-mail: [sales@cincon.com](mailto:sales@cincon.com)  
Web Site: <https://www.cincon.com>

**Factory:**

No. 8-1, Fu Kung Rd.  
Fu Hsing Industrial Park  
Fu Hsing Hsiang,  
ChangHua Hsien, Taiwan  
Tel: 886-4-7690261  
Fax: 886-4-7698031

**Cincon North America:**

1655Mesa Verde Ave. Ste 180  
Ventura, CA93003  
Tel: 805-639-3350  
Fax: 805-639-4101  
E-mail: [info@cincon.com](mailto:info@cincon.com)