

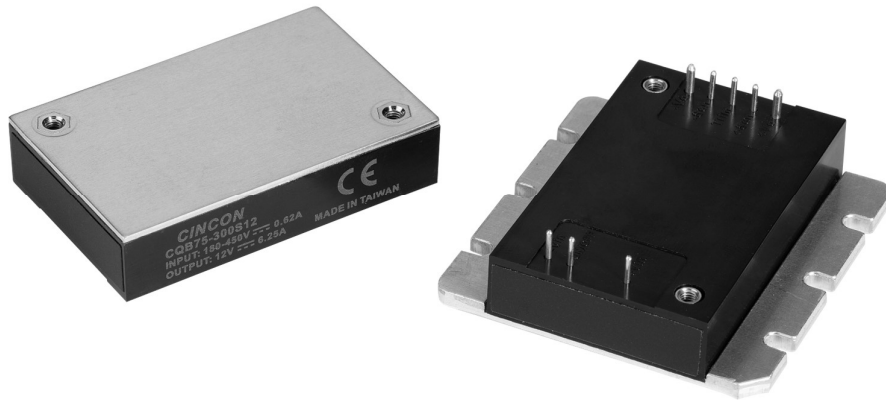

CQB75-300S Series Application Note V12

ISOLATED DC-DC CONVERTER CQB75-300S SERIES APPLICATION NOTE



Approved By:

Department	Approved By	Checked By	Written By
Research and Development Department	Jacky	Astray	Joe
Design Quality Department	Benny	JoJo	



CQB75-300S Series Application Note V12

Contents

1. Introduction	3
2. Pin Function Description	3
3. Connection for Standard Use	4
4. Test Set-Up	4
5. Recommend Layout, PCB Footprint and Soldering Information.....	4
6. Features and Functions	5
6.1 UVLO (Under Voltage Lock Out)	5
6.2 Over Current / Short Circuit Protection	5
6.3 Output Over Voltage Protection	5
6.4 Over Temperature Protection.....	6
6.5 Remote On/Off	6
6.6 Output Remote Sensing.....	6
6.7 Output Voltage Adjustment	7
7. Input / Output Considerations	9
7.1 Input Capacitance at the Power Module	9
7.2 Output Ripple and Noise	9
7.3 Output Capacitance	10
8. Series and Parallel Operation	10
8.1 Series Operation	10
8.2 Parallel Operation	10
8.3 Redundant Operation.....	11
9. Thermal Design.....	12
9.1 Operating Temperature Range	12
9.2 Convection Requirements for Cooling	12
9.3 Thermal Considerations	12
9.4 Power Derating	12
9.5 Quarter Brick Heat Sinks.....	14
10. Safety & EMC	15
10.1 Input Fusing and Safety Considerations	15
10.2 EMC Considerations	15



CQB75-300S Series Application Note V12

1. Introduction

The CQB75-300S series of DC-DC converters offers 75 watts of output power @ single output voltages of 3.3, 5, 12, 15, 24, 48VDC with industry standard quarter-brick. It has a wide (2:1) input voltage range of 180 to 450VDC (300VDC nominal) and 3000VAC reinforced isolation.

Compliant with EN55032, EN45545. High efficiency up to 90%, allowing case operating temperature range of -40°C to 105°C (except M2 Series - 55°C to 105°C). An optional heat sink is available to extend the full power range of the unit. Very low no load power consumption (8mA), an ideal solution for energy critical systems.

The standard control functions include remote on/off (positive or negative) and +20%, -20% (Except for 3.3Vout& 5Vout) adjustable output voltage.

Fully protected against input UVLO (under voltage lock out), output over-current, output over-voltage and over-temperature and continuous short circuit conditions.

CQB75-300S series is highly suitable for distributed power architectures, telecommunications, servers, base station, battery operated equipment, and industrial applications.

2. Pin Function Description

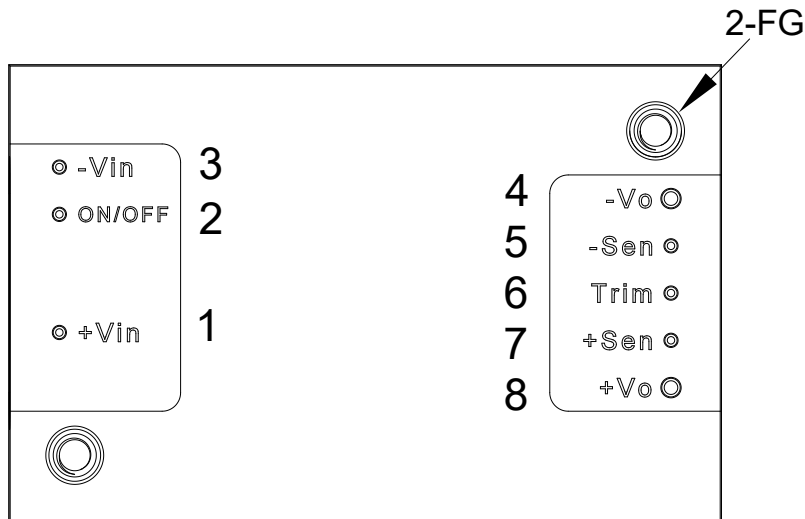

No	Label	Function	Description	Reference
1	+Vin	+V Input	Positive Supply Input	Section 7.1
2	ON/OFF	On/Off	External Remote On/Off Control	Section 6.5
3	-Vin	-V Input	Negative Supply Input	Section 7.1
4	-Vo	-V Output	Negative Power Output	Section 7.2/7.3
5	-Sen	-Sense	Negative Output Remote Sense	Section 6.6
6	Trim	Trim	External Output Voltage Adjustment	Section 6.7
7	+Sen	+Sense	Positive Output Remote Sense	Section 6.6
8	+Vo	+V Output	Positive Power Output	Section 7.2/7.3
--	--	Mounting Insert	Mounting Insert (FG)	Section 9.5/10.2

Note: Base plate can be connected to FG through M3 threaded mounting insert. Recommended torque 3Kgf-cm.



CQB75-300S Series Application Note V12

3. Connection for Standard Use

The connection for standard use is shown below. An external input capacitor (C1) 33uF for all models is recommended to reduce input ripple voltage. External output capacitors (C2, C3) and a Y capacitor (C4) are recommended to reduce output ripple and noise, 10uF aluminum solid, 1uF ceramic capacitor for all models.

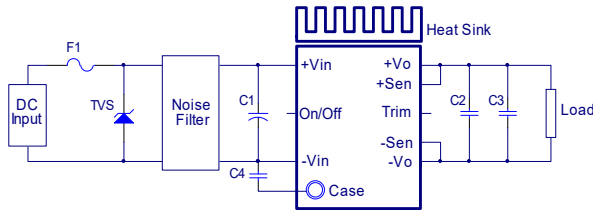

Symbol	Component	Reference
F1, TVS	Input fuse, TVS	Section 10.1
C1	External capacitor on input side	Note 1 Section 7.2
C2,C3	External capacitor on the output side	Section 7.2/7.3
C4	External capacitor on the case	Note 2 Section 7.2
Noise Filter	External input noise filter	Section 10.2
Remote On/Off	External Remote On/Off control	Section 6.5
Trim	External output voltage adjustment	Section 6.7
Heat sink	External heat sink	Section 9.2/9.3/9.4/9.5
+Sense/-Sense	--	Section 6.6

Note:

- If the impedance of input line is high, C1 capacitance must be more than above. Use more than two recommended capacitor above in parallel when ambient temperature becomes lower than -20°C.
- Disc ceramic capacitor 1000pF (type KX Class X1 Y1 series Murata)

4. Test Set-Up

The basic test set-up to measure parameters such as efficiency and load regulation is shown below. When testing the modules under any transient conditions please ensure that the transient response of the source is sufficient to power the equipment under test. We can calculate:

- Efficiency
- Load regulation and line regulation

The value of efficiency is defined as:

$$\eta = \frac{V_o \times I_o}{V_{in} \times I_{in}} \times 100\%$$

Where:

V_o is output voltage

I_o is output current

V_{in} is input voltage

I_{in} is input current

The value of load regulation is defined as:

$$Load\ reg. = \frac{V_{FL} - V_{NL}}{V_{NL}} \times 100\%$$

Where:

V_{FL} is the output voltage at full load

V_{NL} is the output voltage at no load

The value of line regulation is defined as:

$$Line\ reg. = \frac{V_{HL} - V_{LL}}{V_{LL}} \times 100\%$$

Where:

V_{HL} is the output voltage of maximum input voltage at full load

V_{LL} is the output voltage of minimum input voltage at full load

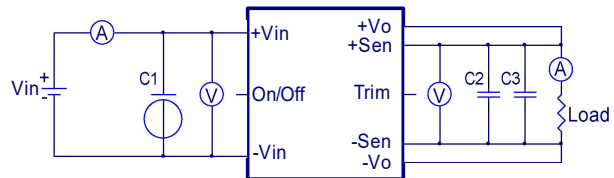

CQB75-300S Series Test Setup

C1: 33uF/500V ESR<4Ω

C2: 1uF/1210 ceramic capacitor

C3: 10uF aluminum solid capacitor

5. Recommend Layout, PCB Footprint and Soldering Information

The system designer or end user must ensure that metal and other components in the vicinity of the converter meet the spacing requirements for which the system is approved. Low resistance and inductance PCB layout traces are the norm and should be used where possible. Due consideration must also be given to proper low impedance tracks between power module, input and output grounds.



CQB75-300S Series Application Note V12

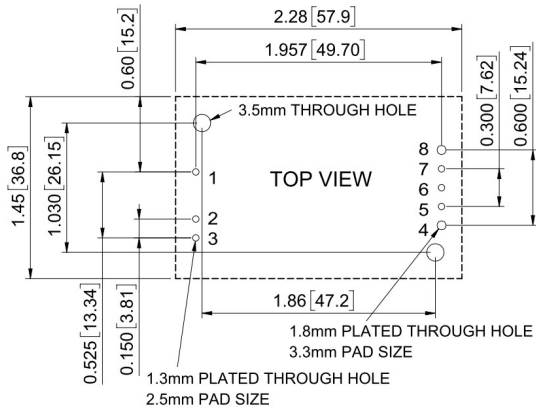

Clean the soldered side of the module with a brush, prevent liquid from getting into the module. Do not clean by soaking the module into liquid. Do not allow solvent to come in contact with product labels or resin case as this may change the color of the resin case or cause deletion of the letters printed on the product label. After cleaning, dry the modules well.

The suggested soldering iron is 450°C for up to 5 seconds (less than 50W). Furthermore, the recommended soldering profile is shown below, and PCB layout is referring to **Section 10.2**.

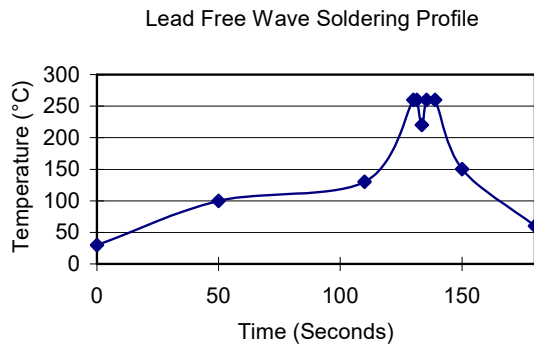

6. Features and Functions

6.1 UVLO (Under Voltage Lock Out)

Input under voltage lockout is standard on the CQB75-300S series unit. The unit will shut down when the input voltage drops below a threshold, and the unit will operate when the input voltage goes above the upper threshold.

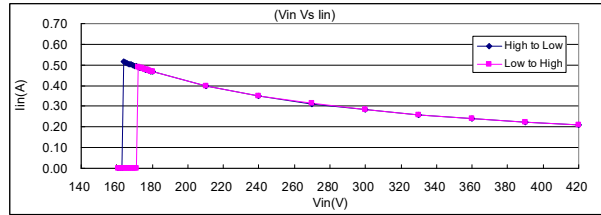

6.2 Over Current / Short Circuit Protection

All models have internal over current and continuous short circuit protection. The unit operates normally once the fault condition is removed. At the point of current limit inception, the converter will go into hiccup mode protection.

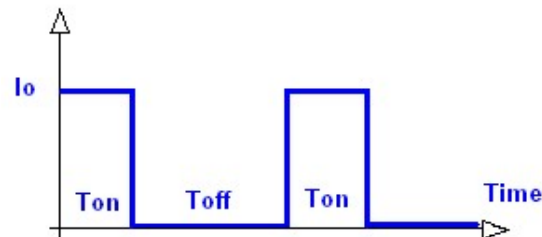
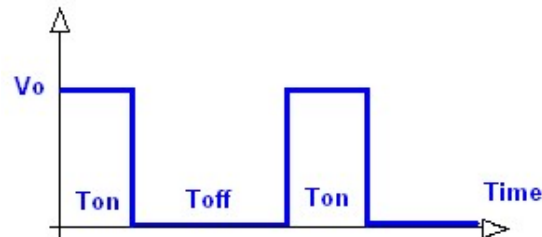

6.3 Output Over Voltage Protection

The output over voltage protection consists of circuitry that internally limits the output voltage. If more accurate output over voltage protection is required, then an external circuit can be used via the remote on/off pin.

Note: Please note that device inside the power supply might fail when voltage more than rate output voltage is applied to output pin. This could happen when the customer tests the over voltage protection of unit. OVP can be tested by using the TRIM UP function. Consult us for more information.



CQB75-300S Series Application Note V12

6.4 Over Temperature Protection

These modules have an over temperature protection circuit to safeguard against thermal damage. Shutdown occurs with the maximum case reference temperature is exceeded. The module will restart when the case temperature falls below over temperature recovery threshold. Please measure case temperature of the center part of aluminum base plate.

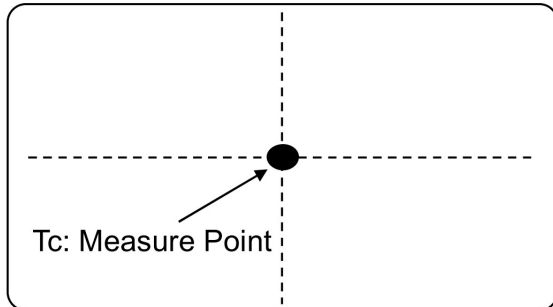
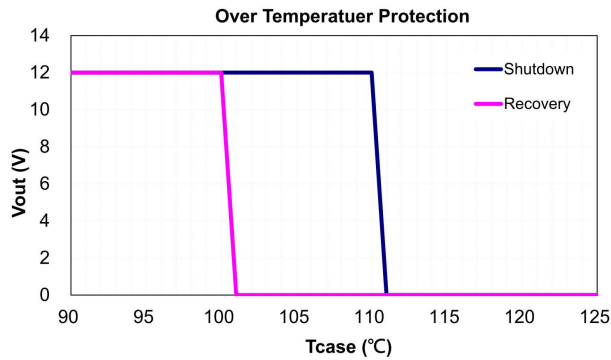

6.5 Remote On/Off

The CQB75-300S series allows the user to switch the module on and off electronically with the remote On/Off feature. All models are available in “positive logic” and “negative logic” (optional) versions. The converter turns on if the remote On/Off pin is high (>3.5Vdc to 75Vdc or open circuit). Setting the pin low (0 to <1.2Vdc, except M2 Series is 0 to <1.0Vdc) will turn the converter off. The signal level of the remote On/Off input is defined with respect to ground. If not using the remote On/Off pin, leave the pin open (converter will be on). Models with part number suffix “N” are the “negative logic” remote On/Off version. The unit turns off if the remote On/Off pin is high (>3.5Vdc to 75Vdc or open circuit). The converter turns on if the On/Off pin input is low (0 to <1.2Vdc, except M2 Series is 0 to <1.0Vdc). Note that the converter is off by default.

Logic State (Pin 2)	Negative Logic	Positive Logic
Logic Low	Module on	Module off
Logic High	Module off	Module on

The converter remote On/Off circuit built-in on input side. The ground pin of input side Remote On/Off circuit is – Vin pin. Inside connection sees below.

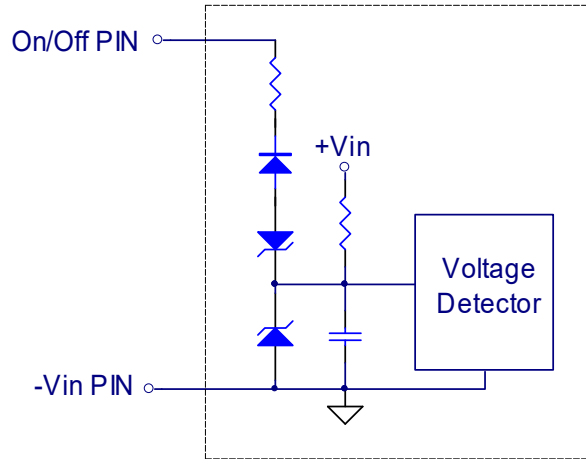

Connection examples see below.

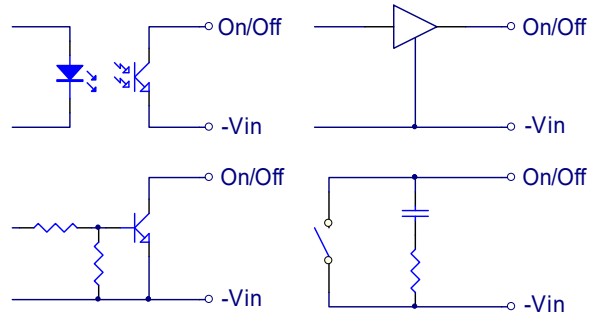

Remote On/Off Connection Example

6.6 Output Remote Sensing

The CQB75-300S series converter has the capability to remotely sense both lines of its output. This feature moves the effective output voltage regulation point from the output of the unit to the point of connection of the remote sense pins. This feature automatically adjusts the real output voltage of the CQB75-300S series in order to compensate for voltage drops in distribution and maintain a regulated voltage at the point of load. The remote-sense voltage range is:

$$[(+V_{out}) - (-V_{out})] - [(+Sense) - (-Sense)] \leq 20\% \\ (3.3V_{out} \& 05V_{out}: \leq 10\%) \text{ of } V_{o_nominal}$$

When remote sense is in use, the sense should be connected by twisted-pair wire or shield wire. If the sensing patterns short, heavy current flows and the pattern may be damaged. Output voltage might become unstable because of impedance of wiring and load condition when length of wire is exceeding 400mm. This is shown in the schematic below.



CQB75-300S Series Application Note V12

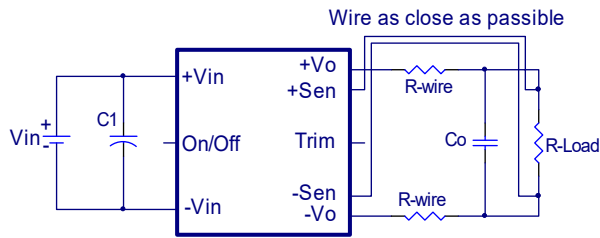

If the remote sense feature is not to be used, the sense pins should be connected locally. The +Sense pin should be connected to the +Vout pin at the module and the -Sense pin should be connected to the -Vout pin at the module. Wire between +Sense and +Vout and between -Sense and -Vout as short as possible. Loop wiring should be avoided. The converter might become unstable by noise coming from poor wiring. This is shown in the schematic below.

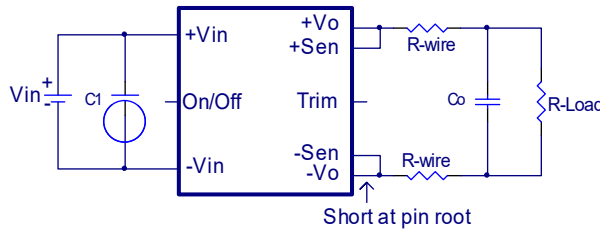

Note:
Although the output voltage can be varied (increased or decreased) by both remote sense and trim, the maximum variation for the output voltage is the larger of the two values not the sum of the values. The output power delivered by the module is defined as the voltage at the output terminals multiplied by the output current. Using remote sense and trim can cause the output voltage to increase and consequently increase the power output of the module if output current remains unchanged. Always ensure that the output power of the module remains at or below the maximum rated power. Also be aware that if $V_{o,set}$ is below nominal value, $P_{out,max}$ will also decrease accordingly because $I_{o,max}$ is an absolute limit. Thus, $P_{out,max} = V_{o,set} \times I_{o,max}$ is also an absolute limit.

6.7 Output Voltage Adjustment

Output may be externally trimmed (-20% to +20% except for 3.3Vout & 5Vout) with a fixed resistor or an external trim pot as shown (optional). Model specific formulas for calculating trim resistors are available upon request as a separate document.

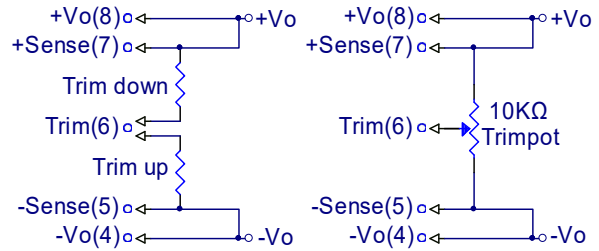

In order to trim the voltage up or down, one needs to connect the trim resistor either between the trim pin and -Sense for trim-up or between trim pin and +Sense for trim-down. The output voltage trim range is -20% to +20% ($3.3V_{out}$ & $5V_{out}$: -20% to +10%). This is shown:

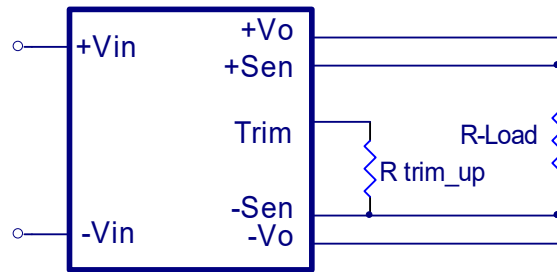

Trim-up Voltage Setup

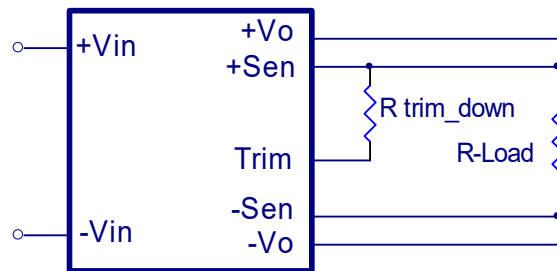

Trim-down Voltage Setup

The value of R_{trim_up} defined as:

$$R_{trim_up} = \left[\frac{V_r \times R1 \times (R2 + R3)}{R2 \times (V_o - V_{o,nom})} \right] - R_t \text{ (K}\Omega\text{)}$$

Where:

R_{trim_up} is the external resistor in K Ω .

$V_{o,nom}$ is the nominal output voltage.

V_o is the desired output voltage.

$R1, R2, R3, R_t$ and V_r are internal to the unit and are defined in Table 1.



CQB75-300S Series Application Note V12

Table 1 – Trim up and Trim down Resistor Values

Model Number	Output Voltage(V)	R1 (KΩ)	R2 (KΩ)	R3 (KΩ)	Rt (KΩ)	Vr (V)
CQB75-300S3V3	3.3	See Note1			0.62	1.24
CQB75-300S05	5.0	See Note2			1.5	2.5
CQB75-300S12	12.0	6.8	2.37	2.2	10	2.5
CQB75-300S15	15.0	9.1	2.35 9	2.7	12	2.5
CQB75-300S24	24.0	15	2.43	5.9	20	2.5
CQB75-300S48	48.0	28.7	2.4	15	43.2	2.5

For example, to trim-up the output voltage of 12V module (CQB75-300S12) by 20% to 14.4V, R_{trim_up} is calculated as follows:

$$R1=6.8K\Omega, R2=2.37K\Omega, R3=2.2K\Omega, Rt=10K\Omega, Vr=2.5V, Vo=14.4V, Vo, nom=12V$$

$$R_{trim_up} =$$

$$\left[\frac{2.5 \times 6.8 \times (2.37 + 2.2)}{2.37 \times (14.4 - 12)} \right] - 10 = 3.65 (K\Omega)$$

The typical value of R_{trim_up}

Trim up (%)	3.3V	05V	12V	15V	24V	48V
	$R_{trim_up} (K\Omega)$					
1%	13.36	27.90	263.17	313.26	515.62	1040.52
2%	6.22	12.90	126.59	150.63	247.81	498.66
3%	3.84	7.90	81.06	96.42	158.54	318.04
4%	2.65	5.40	58.29	69.31	113.91	227.73
5%	1.94	3.90	44.63	53.05	87.12	173.54
6%	1.46	2.90	35.53	42.21	69.27	137.42
7%	1.12	2.19	29.03	34.47	56.52	111.62
8%	0.87	1.65	24.15	28.66	46.95	92.27
9%	0.67	1.23	20.35	24.14	39.51	77.21
10%	0.51	0.90	17.32	20.53	33.56	65.17
11%			14.83	17.57	28.69	55.32
12%			12.76	15.10	24.64	47.11
13%			11.01	13.02	21.20	40.16
14%			9.51	11.23	18.26	34.21
15%			8.21	9.68	15.71	29.05
16%			7.07	8.33	13.48	24.53
17%			6.07	7.13	11.51	20.55
18%			5.17	6.07	9.76	17.01
19%			4.38	5.12	8.19	13.84
20%			3.66	4.26	6.78	10.99

The value of R_{trim_down} defined as:

$$R_{trim_down} =$$

$$R1 \times \left[\frac{Vr \times R1}{R2 \times (Vo, nom - Vo)} - 1 \right] - Rt (K\Omega)$$

Where:

R_{trim_down} is the external resistor in KΩ.

Vo, nom is the nominal output voltage.

Vo is the desired output voltage.

R1, R2, R3, Rt and Vr are internal to the unit and are defined in Table 1.

For example: to trim-down the output voltage of 12V module (CQB75-300S12) by 20% to 9.6V, R_{trim_down} is calculated as follows:

$$R1=6.8K\Omega, R2=2.37K\Omega, R3=2.2K\Omega, Rt=10K\Omega, Vr=2.5V, Vo=9.6V, Vo, nom=12V$$

$$R_{trim_down} =$$

$$6.8 \times \left[\frac{2.5 \times 6.8}{2.37 \times (12 - 9.6)} - 1 \right] - 10 = 3.52 (K\Omega)$$

Note1: CQB75-300S3V3 calculated as follows:

$$R_{trim_down} =$$

$$\left[\frac{1.94 \times Vr - 1.17 \times (Vo - Vo, nom)}{(Vo, nom - Vo)} \right] - Rt (K\Omega)$$

$$R_{trim_up} =$$

$$\left[\frac{0.38 \times Vr - 0.30 \times (Vo - Vo, nom)}{(Vo - Vo, nom)} \right] - Rt (K\Omega)$$

Note2: CQB75-300S05 calculated as follows:

$$R_{trim_down} =$$

$$\left[\frac{1.8 \times Vr - 1.8 \times (Vo - Vo, nom)}{(Vo, nom - Vo)} \right] - Rt (K\Omega)$$

$$R_{trim_up} =$$

$$\left[\frac{0.6 \times Vr - 0.6 \times (Vo - Vo, nom)}{(Vo - Vo, nom)} \right] - Rt (K\Omega)$$



CQB75-300S Series Application Note V12

The typical value of R_{trim_down}

Trim down (%)	3.3V	05V	12V	15V	24V	48V
	R_{trim_down} (K Ω)					
1%	71.11	86.70	389.67	563.96	929.51	1715.62
2%	34.66	41.70	186.44	271.43	447.25	821.86
3%	22.51	26.70	118.69	173.92	286.50	523.94
4%	16.43	19.20	84.81	125.17	206.13	374.98
5%	12.79	14.70	64.49	95.91	157.90	285.60
6%	10.36	11.70	50.95	76.41	125.75	226.02
7%	8.62	9.55	41.27	62.48	102.79	183.46
8%	7.32	7.95	34.01	52.03	85.56	151.54
9%	6.31	6.70	28.36	43.91	72.17	126.71
10%	5.50	5.700	23.85	37.41	61.45	106.85
11%	4.84	4.88	20.15	32.09	52.68	90.60
12%	4.29	4.20	17.07	27.66	45.38	77.06
13%	3.82	3.62	14.47	23.90	39.19	65.60
14%	3.42	3.13	12.24	20.69	33.89	55.78
15%	3.07	2.70	10.30	17.90	29.30	47.27
16%	2.77	2.33	8.60	15.47	25.28	39.82
17%	2.50	1.99	7.11	13.32	21.74	33.25
18%	2.26	1.70	5.78	11.40	18.58	27.41
19%	2.05	1.44	4.59	9.69	15.76	22.18
20%	1.86	1.20	3.52	8.15	13.23	17.48

7. Input / Output Considerations

7.1 Input Capacitance at the Power Module

The converters must be connected to low AC source impedance. To avoid problems with loop stability source inductance should be low. Also, the input capacitors (C_{in}) should be placed close to the converter input pins to de-couple distribution inductance. However, the external input capacitors are chosen for suitable ripple handling capability. Low ESR capacitors are good choice. Circuit as shown as below represents typical measurement methods for reflected ripple current. C_1 and L_1 simulate a typical DC source impedance. The input reflected-ripple current is measured by current probe to oscilloscope with a simulated source Inductance (L_1).

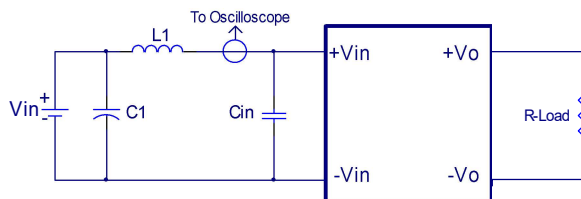

L_1 : 12 μ H

C_1 & C_{in} : 68 μ F ESR<1ohm @100KHz

7.2 Output Ripple and Noise

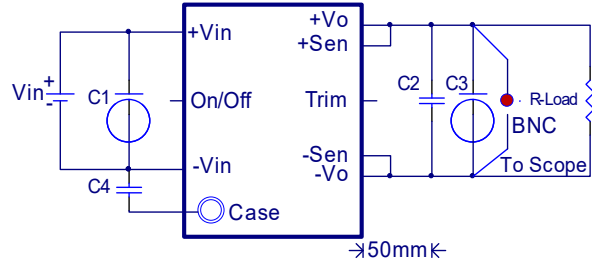

Output ripple and noise

C_1 : 33 μ F/500V ESR<4 Ω

C_2 : 1 μ F/1210 ceramic capacitor

C_3 : 10 μ F aluminum solid capacitor.

C_4 : Disc ceramic capacitor 1000pF (type KX Class X1 Y1 series Murata)

Output ripple and noise measured with 10 μ F aluminum solid and 1 μ F ceramic capacitors across output. A 20 MHz bandwidth oscilloscope is normally used for the measurement.

The conventional ground clip on an oscilloscope probe should never be used in this kind of measurement. This clip, when placed in a field of radiated high frequency energy, acts as an antenna or inductive pickup loop, creating an extraneous voltage that is not part of the output noise of the converter.

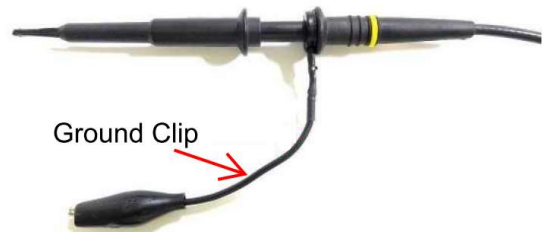

Another method is shown in below, in case of coaxial-cable/BNC is not available. The noise pickup is eliminated by pressing scope probe ground ring directly against the -Vout terminal while the tip contacts the +Vout terminal. This makes the shortest possible connection across the output terminals.

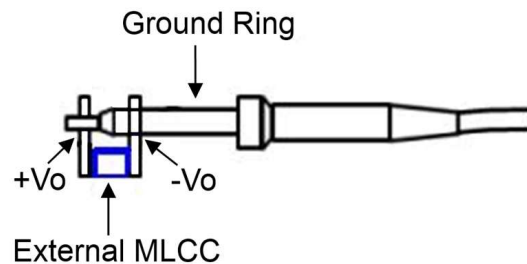



CQB75-300S Series Application Note V12

7.3 Output Capacitance

The CQB75-300S series converters provide unconditional stability with or without external capacitors. For good transient response, low ESR output capacitors should be located close to the point of load (<100mm). PCB design emphasizes low resistance and inductance tracks in consideration of high current applications. Output capacitors with their associated ESR values have an impact on loop stability and bandwidth. Cincon's converters are designed to work with load capacitance to see specifications.

8. Series and Parallel Operation

8.1 Series Operation

Series operation is possible by connecting the outputs two or more units. Connection is shown in below. The output current in series connection should be lower than the lowest rate current in each power module.

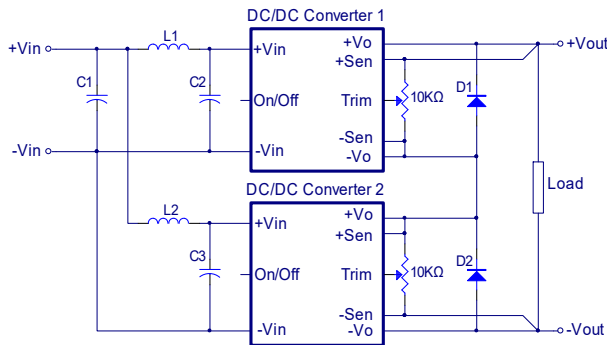

Simple Series Operation Connect Circuit

L1, L2: 1.0uH

C1, C2, C3: 33uF/500V ESR<4Ω

Note:

1. If the impedance of input line is high, C1, C2, C3 capacitance must be more than above. Use more than two recommended capacitor above in parallel when ambient temperature becomes lower than -20°C.
2. Recommend Schottky diode(D1, D2) be connected across the output of each series connected converter, so that if one converter shuts down for any reason, then the output stage won't be thermally overstressed. Without this external diode, the output stage of the shut-down converter could carry the load current provided by the other series converters, with its MOSFETs conducting through the body diodes. The MOSFETs could then be overstressed and fail. The external diode should be capable of handling the full load current for as long as the application is expected to run with any unit shut down.

Series for \pm output operation is possible by connecting the outputs two units, as shown in the schematic below.

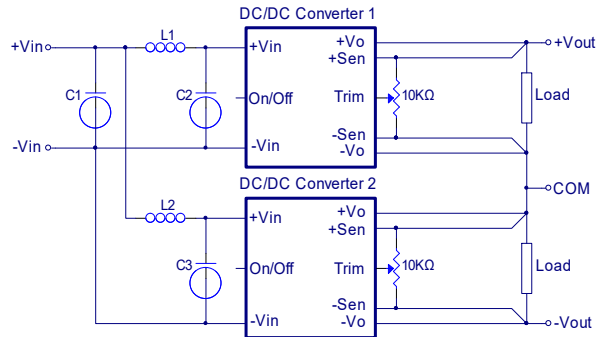

Simple \pm Output Operation Connect Circuit

L1, L2: 1.0uH

C1, C2, C3: 33uF/500V ESR<4Ω

Note:

If the impedance of input line is high, C1, C2, C3 capacitance must be more than above. Use more than two recommended capacitor above in parallel when ambient temperature becomes lower than -20°C.

8.2 Parallel Operation

The CQB75-300S series parallel operation is **not** possible.



CQB75-300S Series Application Note V12

8.3 Redundant Operation

Parallel for redundancy operation is possible by connecting the units as shown in the schematic below. The current of each converter become unbalance by a slight difference of the output voltage. Make sure that the output voltage of units of equal value and the output current from each power supply does not exceed the rate current. Suggest use an external potentiometer to adjust output voltage from each power supply.

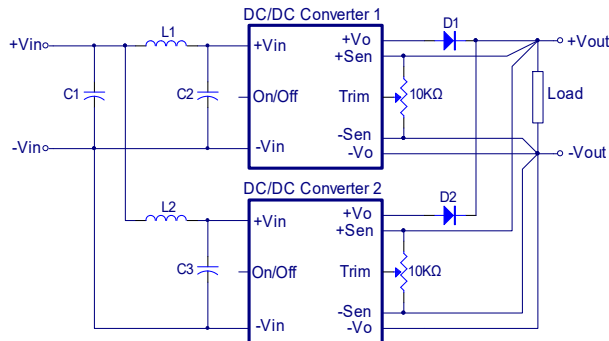

Simple Redundant Operation Connect Circuit

L1, L2: 1.0uH

C1, C2, C3: 33uF/500V ESR<4Ω

Note:

If the impedance of input line is high10., C1, C2, C3 capacitance must be more than above. Use more than two recommended capacitor above in parallel when ambient temperature becomes lower than -20°C.



CQB75-300S Series Application Note V12

9. Thermal Design

9.1 Operating Temperature Range

The CQB75-300S series converters can be operated within a wide case temperature range of -40°C to 105°C. Consideration must be given to the derating curves when ascertaining maximum power that can be drawn from the converter. The maximum power drawn from open quarter brick models is influenced by usual factors, such as:

- Input voltage range
- Output load current
- Forced air or natural convection
- Heat sink optional

9.2 Convection Requirements for Cooling

To predict the approximate cooling needed for the quarter brick module, refer to the power derating curves in **section 9.4**. These derating curves are approximations of the ambient temperatures and airflows required to keep the power module temperature below its maximum rating. Once the module is assembled in the actual system, the module's temperature should be monitored to ensure it does not exceed 105°C as measured at the center of the top of the case (thus verifying proper cooling).

9.3 Thermal Considerations

The power module operates in a variety of thermal environments; however, sufficient cooling should be provided to help ensure reliable operation of the unit. Heat is removed by conduction, convection, and radiation to the surrounding environment. The example is presented in **section 9.4**. The power output of the module should not be allowed to exceed rated power ($V_{o_set} \times I_{o_max}$).

9.4 Power Derating

The operating case temperature range of CQB75-300S series is -40°C to +105°C. When operating the CQB75-300S series, proper derating or cooling is needed. The maximum case temperature under any operating condition should not exceed 105°C.

The following curve is the de-rating curve of CQB75-300S series without heat sink.

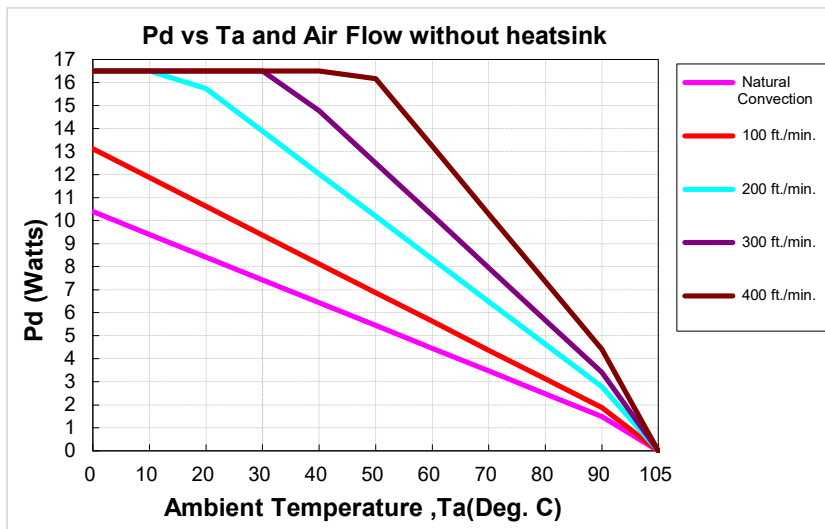

AIR FLOW RATE	TYPICAL R_{ca}
Natural Convection	10.1 °C/W
20ft./min. (0.1m/s)	10.1 °C/W
100 ft./min. (0.5m/s)	8.0 °C/W
200 ft./min. (1.0m/s)	5.4 °C/W
300 ft./min. (1.5m/s)	4.4 °C/W
400 ft./min. (2.0m/s)	3.4 °C/W



CQB75-300S Series Application Note V12

Example:

What is the minimum airflow necessary for a CQB75-300S15 operating at nominal line voltage, an output current of 5.0A, and a maximum ambient temperature of 50°C?

Solution:

Given: $V_{in}= 300V_{dc}$, $V_o= 15V_{dc}$, $I_o= 5.0A$

Determine Power dissipation (P_d): $P_d= P_i-P_o= P_o(1-\eta)/\eta$, $P_d= 15 \times 5 \times (1-0.895)/0.895= 8.88Watts$

Determine airflow: Given: $P_d= 8.88W$ and $T_a= 50^\circ C$

Check Power Derating curve: Minimum airflow= 200 ft./min.

Verify:

Maximum temperature rise is $\Delta T= P_d \times R_{ca} = 8.88 \times 5.4=47.95^\circ C$

Maximum case temperature is $T_c = T_a + \Delta T= 97.95^\circ C < 105^\circ C$

Where:

The R_{ca} is thermal resistance from case to ambient environment.

T_a is ambient temperature and T_c is case temperature.

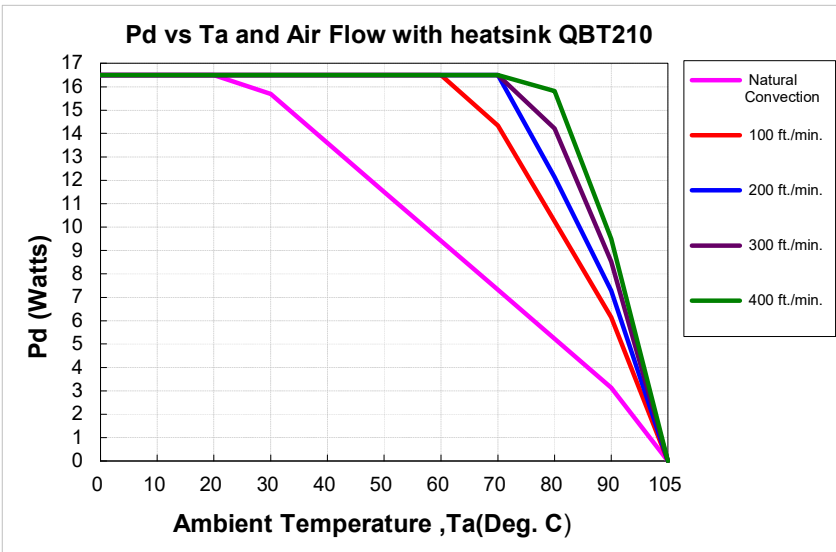

AIR FLOW RATE	TYPICAL R_{ca}
Natural Convection	4.78 °C/W
20ft./min. (0.1m/s)	
100 ft./min. (0.5m/s)	2.44 °C/W
200 ft./min. (1.0m/s)	2.06 °C/W
300 ft./min. (1.5m/s)	1.76 °C/W
400 ft./min. (2.0m/s)	1.58 °C/W

Example with heat sink QBT210 (M-C421):

What is the minimum airflow necessary for a CQB75-300S12 operating at nominal line voltage, an output current of 6.25A, and a maximum ambient temperature of 75°C?

Solution:

Given: $V_{in}= 300V_{dc}$, $V_o= 12V_{dc}$, $I_o= 6.25A$

Determine Power dissipation (P_d): $P_d= P_i-P_o= P_o(1-\eta)/\eta$, $P_d= 12 \times 6.25 \times (1-0.88)/0.88= 10.23Watts$

Determine airflow: Given: $P_d= 10.23W$ and $T_a = 75^\circ C$

Check above Power de-rating curve: Minimum airflow= 100 ft./min

Verify:

Maximum temperature rise is $\Delta T= P_d \times R_{ca}= 10.23 \times 2.44= 24.96^\circ C$

Maximum case temperature is $T_c= T_a + \Delta T= 99.96^\circ C < 105^\circ C$

Where:

The R_{ca} is thermal resistance from case to ambient environment.

T_a is ambient temperature and T_c is case temperature.



CQB75-300S Series Application Note V12

9.5 Quarter Brick Heat Sinks

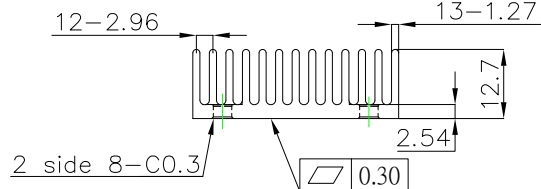
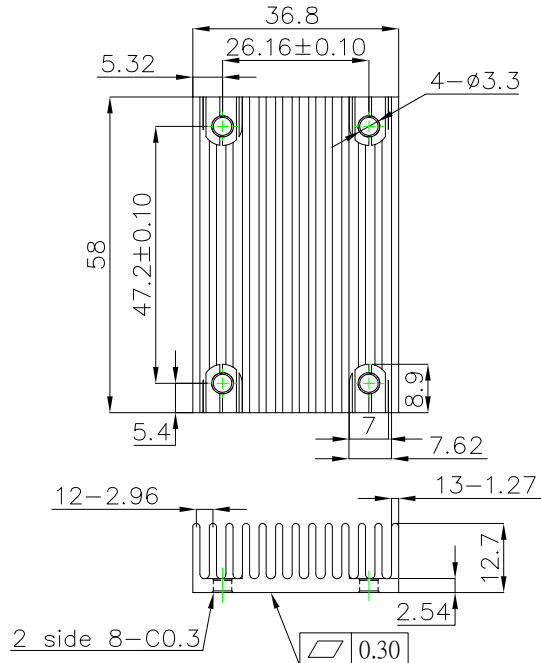
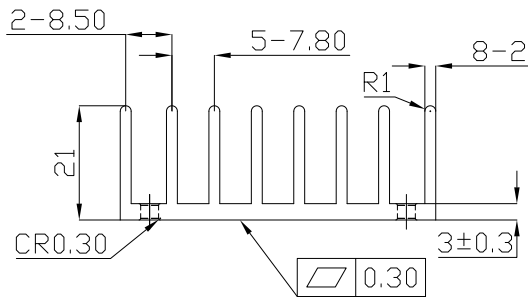
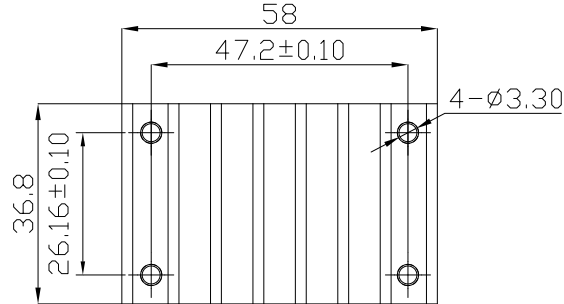

All Dimensions in mm

QBT210 (M-C421) G6620510201 Transverse Heat Sink

- Rca: 4.78°C/W (typ.), At natural convection
- 2.44°C/W (typ.), At 100LFM
- 2.06°C/W (typ.), At 200LFM
- 1.76°C/W (typ.), At 300LFM
- 1.58°C/W (typ.), At 400LFM

QBL127 (M-C448) G6620570202 Longitudinal Heat Sink

- Rca: 5.61°C/W (typ.), At natural convection
- 4.01°C/W (typ.), At 100LFM
- 3.39°C/W (typ.), At 200LFM
- 2.86°C/W (typ.), At 300LFM
- 2.49°C/W (typ.), At 400LFM

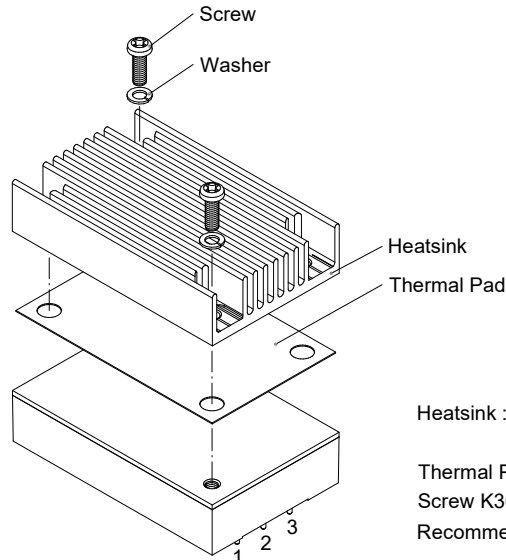

- Heatsink : QBL127 (M-C448)
- QBT210 (M-C421)
- Thermal Pad PQ01: SZ35.8x56.9x0.25mm
- Screw K308W: SMP+SW M3x8L
- Recommended torque 4-8 Kgf-cm



CQB75-300S Series Application Note V12

10. Safety & EMC

10.1 Input Fusing and Safety Considerations

The CQB75-300S series converters have no internal fuse. In order to achieve maximum safety and system protection, always use an input line fuse. We recommended a 1A time delay fuse for all models. It is recommended that the circuit have a transient voltage suppressor diode (TVS) across the input terminal to protect the unit against surge or spike voltage and input reverse voltage (as shown).

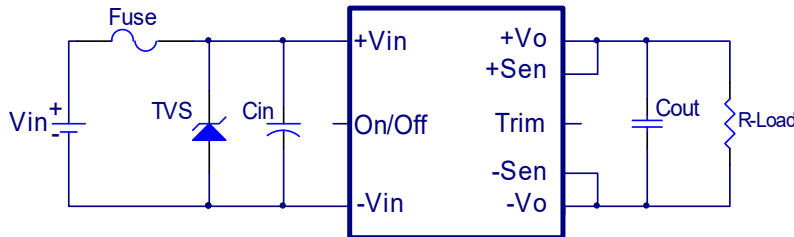

The external input capacitor (Cin) and transient voltage suppressor diode (TVS) are required if CQB75-300S series has to meet EN61000-4-4, EN61000-4-5.

The Cin recommended a 33uF/500V (Nichcon CY series) aluminum capacitor. And the TVS recommended a 1.5KE550CA transient voltage suppressor.

10.2 EMC Considerations

EMI Test standard: EN55032 Class A

Test Condition: Input Voltage: 230Vac, Output Load: Full Load

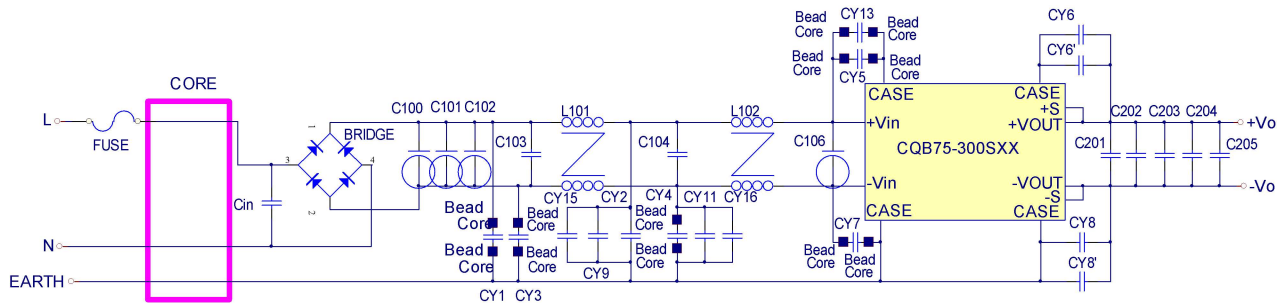

Figure1 Connection circuit

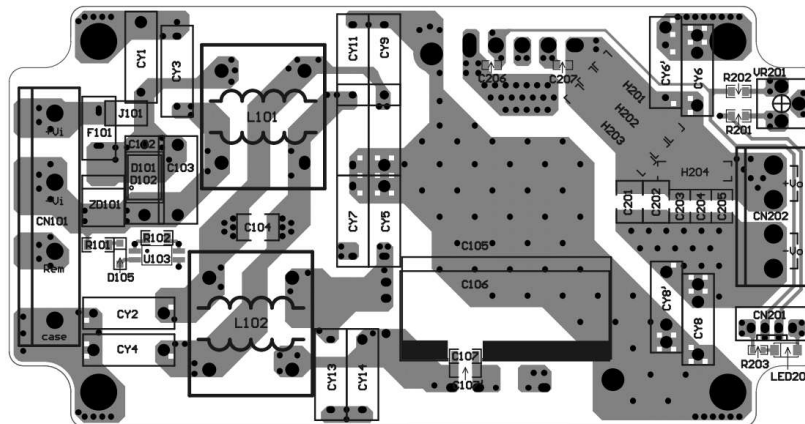

Figure2 PCB layout top view



CQB75-300S Series Application Note V12

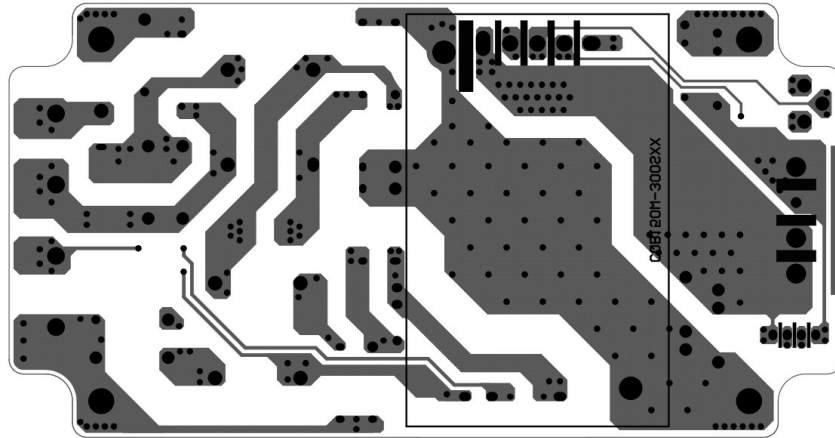

Figure3 PCB layout bottom view

Components value:

	Model Number					
	CQB75-300S3V3	CQB75-300S05	CQB75-300S12	CQB75-300S15	CQB75-300S24	CQB75-300S48
Cin	0.68uF/305Vac 10% MKP62(C42) FARATRONIC					
C100~ C102	100uF/450V KXG aluminum cap					
C103	0.33uF/630VDC Polyester Film Capacitor MPN2 Type HJC					
C104	0.1uF/630V 1812 X7R					
C106	0.33uF/630VDC X2 Capacitor MPN3 Type HJC					
C201, C202	47uF/6.3V 1812 MLCC		4.7uF/100V 1812 MLCC			
C203~ C205	100uF/6.3V 1210 MLCC		2.2uF/100V 1210 MLCC			
CY1	NC	100pF/Y1	220pF/Y1	NC	220pF/Y1	100pF/Y1
CY2	100pF/Y1					
CY3	NC	100pF/Y1				
CY4	220pF/Y1					
CY5	220pF/Y1		100pF/Y1		NC	100pF/Y1
CY6, CY6'	4700pF / Y1					
CY8, CY8'						
CY7						
CY9	NC		470pF/Y1		680pF/Y1	
CY11						
CY13	100pF/Y1		NC			
CY14	NC					
CY15	470pF/Y1					
CY16	470pF/Y1					
L101 L102	0.25*1.0mm/34T 5mH (G91C7523423)					
BEAD CORE	SN030 T2.8*1.7*1.2 SM (G405U698038) CY3, CY4,CY5,CY7,CY13 FOR CQB75-300SS05 CY1 FOR CQB75-300S12					
CORE	KCF-130-B 31.5*31*32.5mm KING CORE (G74E1002305)					



CQB75-300S Series Application Note V12

NOTE:

C103: 630VDC polyester film capacitor MPN2 Type HJC or equivalent.

C104: 1812 ceramic capacitor.

C105: 630VDC X2 capacitor MPN3 Type HJC or equivalent.

CY1-CY5: TDK Y1 capacitor or equivalent.

CY6, CY8: TDK Y1 capacitor or MURATA Y2 capacitors or equivalent.

CY7-CY16: TDK Y1 capacitors or equivalent.

L101, L102: 0.25*1.0mm/34T 5mH YAXIN (G91C7523423).

C201-C202: 1812 ceramic capacitor.

C203-C205: 1210 ceramic capacitor.

EN55032 Class A Conducted Emission CONDUCTION

※Test with Metal Plate Connect to Case and Earth.

Test Standard: **EN55032/55022** Class A Conducted Emission CONDUCTION

CQB75-300S3V3

Line

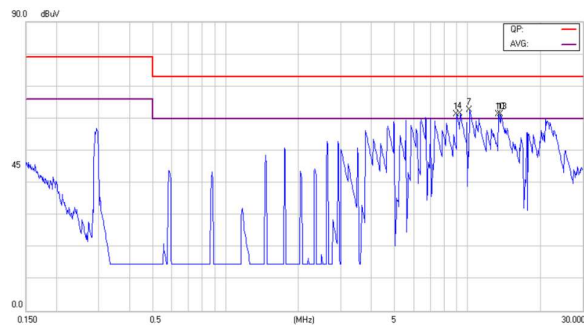

Neutral

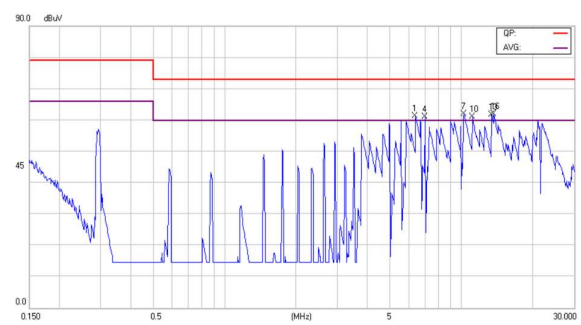

CQB75-300S05

Line

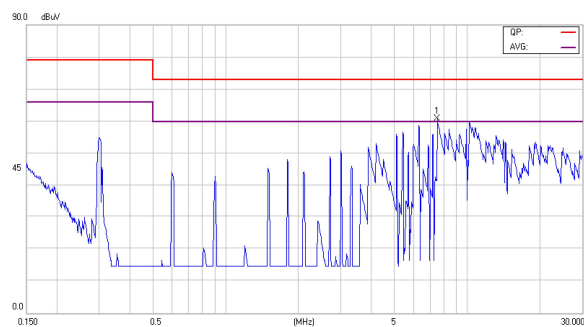

Neutral

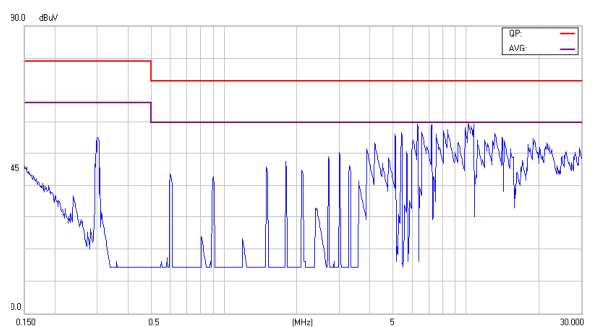



CQB75-300S Series Application Note V12

CQB75-300S12

Line

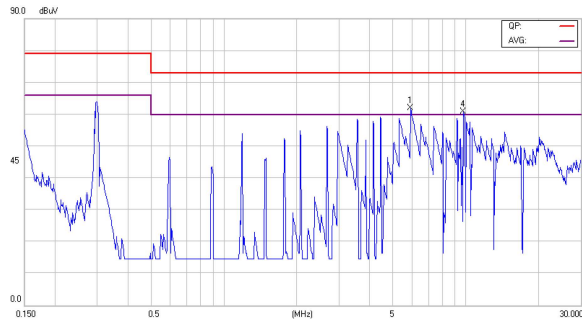

Neutral

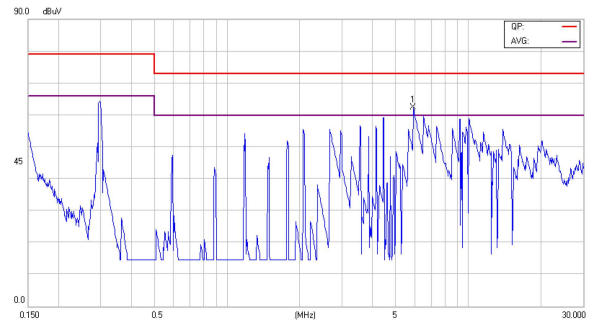

CQB75-300S15

Line

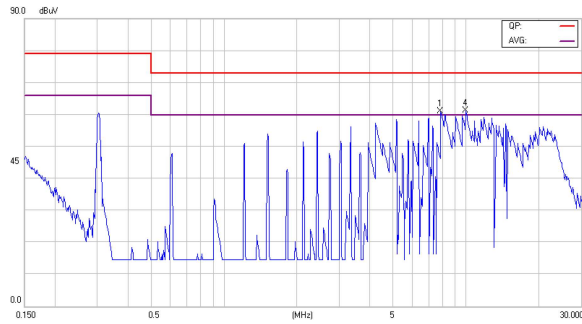

Neutral

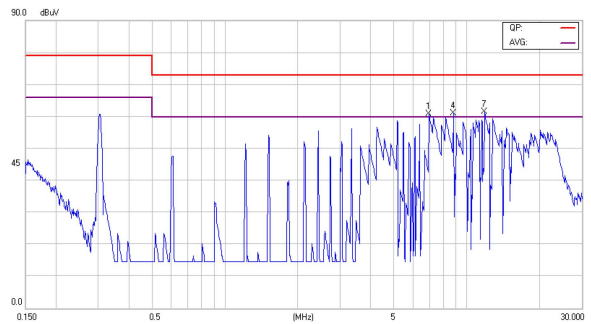

CQB75-300S24

Line

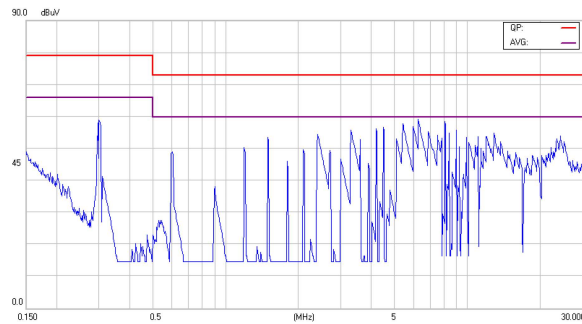

Neutral

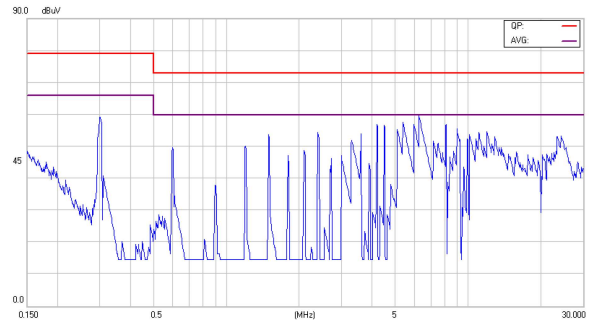



CQB75-300S Series Application Note V12

CQB75-300S48

Line

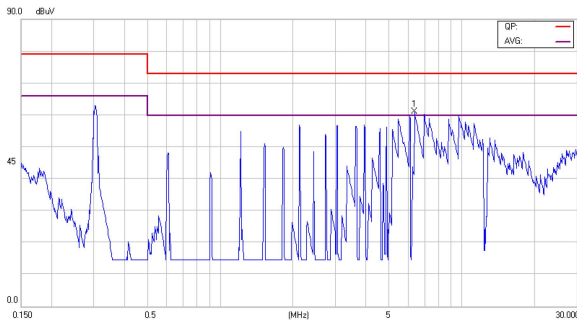

Neutral

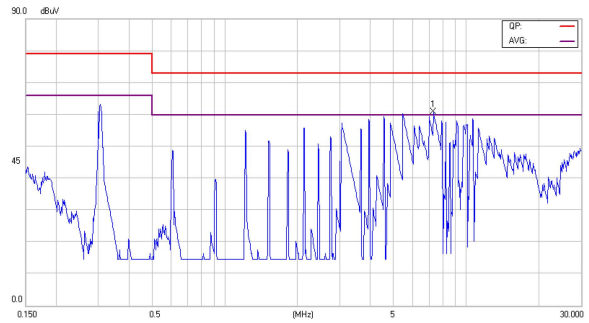

Headquarters:

14F, No.306, Sec.4, Hsin Yi Rd.
Taipei, Taiwan
Tel: 886-2-27086210
Fax: 886-2-27029852
E-mail: sales@cincon.com.tw
Web Site: <https://www.cincon.com>

CINCON ELECTRONICS CO., LTD.

Factory:

No. 8-1, Fu Kung Rd.
Fu Hsing Industrial Park
Fu Hsing Hsiang,
ChangHua Hsien, Taiwan
Tel: 886-4-7690261
Fax: 886-4-7698031

Cincon North America:

1655Mesa Verde Ave. Ste 180
Ventura, CA93003
Tel: 805-639-3350
Fax: 805-639-4101
E-mail: info@cincon.com